

Catálogos

Levante Sistemas de Automatización y Control S.L.



LSA Control S.L. - Bosch Rexroth Sales Partner
Ronda Narciso Monturiol y Estarriol, 7-9
Edificio TecnoParQ Planta 1ª Derecha, Oficina 14
(Parque Tecnológico de Paterna)
46980 Paterna (Valencia)

Telf. (+34) 960 62 43 01

comercial@lsa-control.com

www.lsa-control.com

www.boschrexroth.es



www.lsa-control.com

Distribuidor oficial Bosch Rexroth, Indramat, Bosch y Aventics.

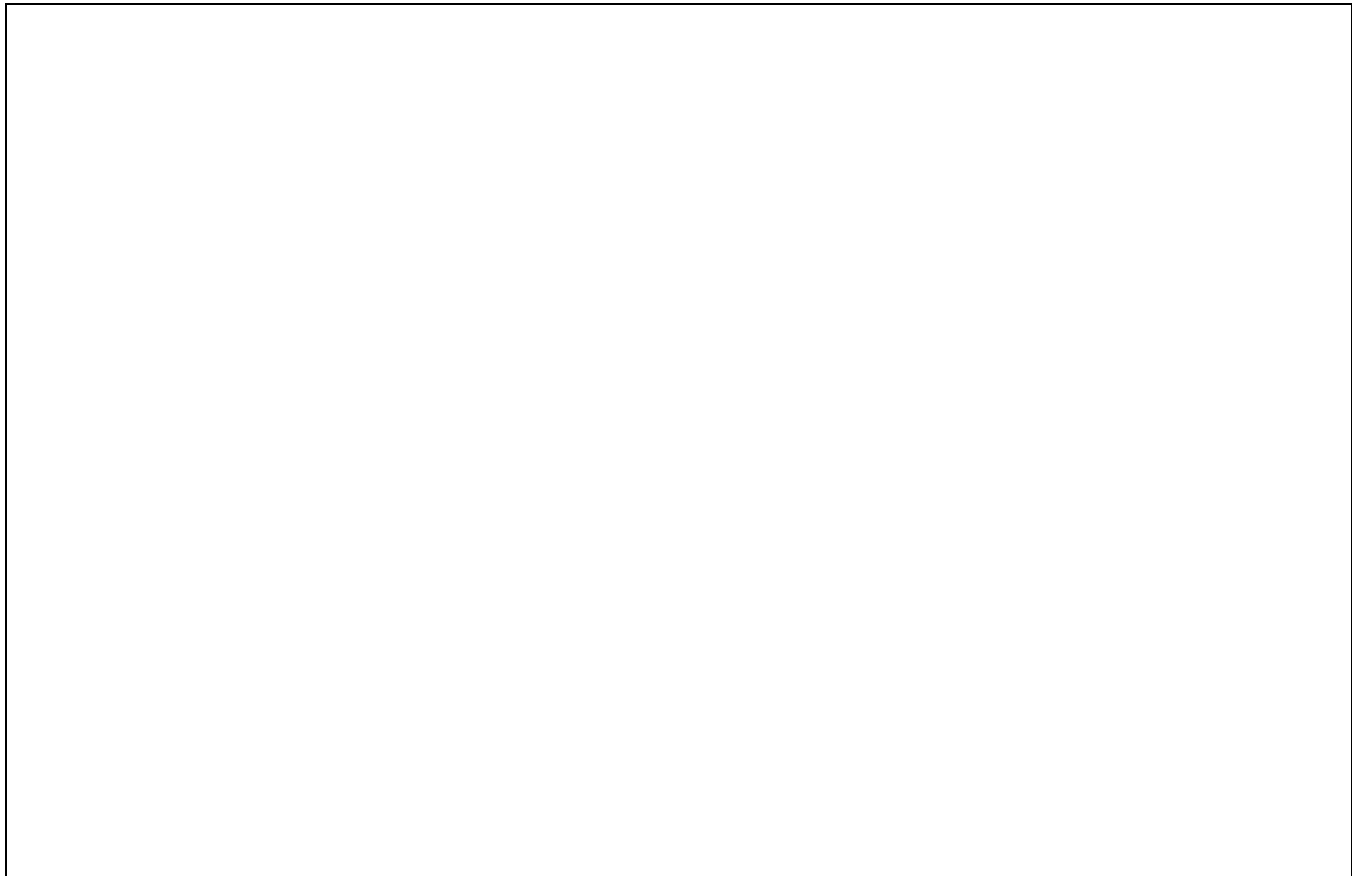

TVR 3.1-W015-03

Power Supply Module for Direct Mains Connection to 3 x AC 380...480 V

Application Manual

DOK-POWER*-TVR*3.1****-ANW1-EN-P



266303

Title TVR 3.1 -W015-03 Power supply module for direct mains connection to 3 x 380 ... 480V

Type of documentation Application Manual

Documenttype DOK-POWER*-TVR*3.1****-ANW1-EN-E1,44 • 10.96

Internal file reference

- Mappe 6
- TVR31-AN.pdf
- 209-0049-4304-00

Purpose of documentation In this document you will find

- the definition of the range of applications
- the electrical layout
- the mechanical layout of the control cabinet
- assembly and installation instructions
- guidance for selecting additional components
- troubleshooting tips

Change procedures

Designation of documentation up to present edition	Release-date	Comments
209-0049-4304-00/05.95	Mai/95	First Edition
DOK-POWER*-TVR*3.1****-ANW1-EN-E1,44	Okt./96	Introduction of document type

Copyright © INDRAMAT GmbH, 1995
 Copying this document, and giving it to others and the use or communication of the contents thereof without express authority, are forbidden. Offenders are liable for the payment of damages. All rights are reserved in the event of the grant of a patent or the registration of a utility model or design (DIN 34-1)

The electronic documentation (E-doc) may be copied as often as needed if such are to be used by the consumer for the purpose intended.

Validity All rights are reserved with respect to the contents of this documentation and the availability of the product.

Published by INDRAMAT GmbH • Bgm.-Dr.-Nebel-Straße 2 • D-97816 Lohr
 Telephone 09352/40-0 • Tx 689421 • Fax 09352/40-4885
 Dept. ENA (DE, FS)

Table of contents	Page
1. The INDRAMAT Modular AC-Drive System	6
1.1. TVR 3.1 power supply module - main functions	7
2. Range of applications	8
2.1. Power ratings	9
2.2. Overload Capacity	9
2.3. TVR 3.1 - data sheet	10
2.4. Environmental conditions	11
2.5. Functional power features	12
3. Electrical connections – installation guidelines	13
3.1. Interconnect diagram	14
3.2. TVR 3.1 interconnect diagram with NAM 1	15
3.3. Mains connection - high voltage section	16
3.4. Fuse protection with direct mains connection	18
3.5. TVR grounding requirements	18
3.6. Commutation Choke	20
3.7. DC bus voltage circuit	20
3.8. DC Bus Choke	21
3.9. Adding capacitance to the DC bus	21
3.10. Additional bleeder module TBM 1.2	21
3.11. Electronics and Fan Supply	22
3.12. Electronics supply buffer capacitor	23
3.13. Electronics supply and signal exchange connections	23
3.14. Current limiting protective devices	24
3.15. Control cabinet testing	25
3.16. Mounting the TVR 3.1 in the control cabinet	25
3.17. Heat loss inside the control cabinet	27
3.18. Bleeder safety clearance inside the control cabinet	27
3.19. Front view of the TVR 3.1	28

4.	TVR 3.1 interconnections	29
4.1.	Options	29
4.2.	TVR interconnect with DC bus short-circuiting	30
4.3.	TVR interconnect with E-stop relay with DC bus short-circuiting ..	32
4.4.	TVR interconnect without DC bus short-circuiting	34
4.5.	TVR interconnect for a position-controlled braking of the drives ...	36
5.	Terminal descriptions	38
5.1.	DC bus short-circuiting	38
5.2.	Power OFF	38
5.3.	Power ON	38
5.4.	Stopping the drives in an E- Stop or a power failure	39
5.5.	Signal voltages	40
5.6.	"Ready" status	40
5.7.	Power OK	42
5.8.	Temperature pre-warning	42
5.9.	TVR mains contactor energized	43
5.10.	TVR mains contactor de-energized	43
6.	Troubleshooting	44
6.1.	Localizing the fault	44
6.2.	Safety Guidelines	44
6.3.	Diagnostic display, fault list	46
6.4.	List of faults and their remedies	47
7.	Dimensions	52
7.1.	Dimension sheet TVR 3.1 power supply module	52
7.2.	Smoothing choke dimension sheet	53
7.3.	Commutation choke dimension sheet	54
7.4.	NAM 1.2 dimension sheet	55
7.5.	TCM 1.1 auxiliary capacitance module	56
7.6.	CZ 1.02 DC bus voltage capacitor	56
7.7.	TBM 1.2 auxiliary bleeder module dimension sheet	57

8. Order information	58
8.1. TVR 3.1 type codes	58
8.2. Available configurations of the TVR 3.1 power supply module and accessories	58
8.3. Overview of electrical accessory kits	59
8.4. Overview 16-pin bus cable for NAM 1.2	59
8.5. Parts list for the TVR 3.1 power supply module	60
9. Index	61

1. The INDRAMAT Modular AC-Drive System

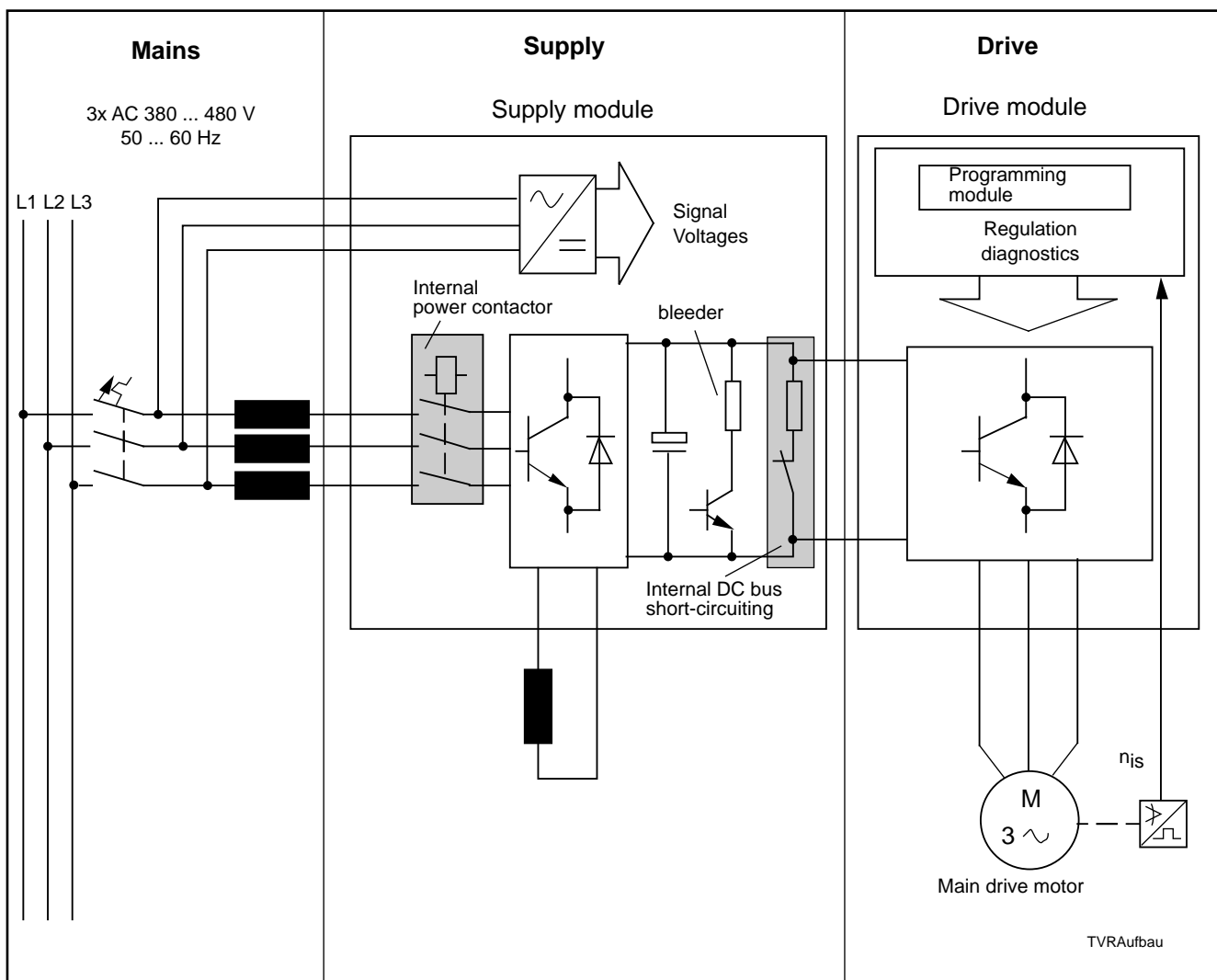

Fig 1.1: TVR 3.1 power supply module as part of the modular INDRAMAT drive system

The INDRAMAT AC drive system consists of a power supply module and a drive module. Several drives can be connected to a single power supply. The TVR 3.1, with its regeneration capability, is a component of the INDRAMAT Modular AC drive system.

The TVR 3.1 provides the DC bus voltage for motor power and control voltages for all connected INDRAMAT main and servo drive modules.

1.1. TVR 3.1 power supply module - main functions

Power source of the drives

The high voltage bridge of the TVR rectifies the three-phase mains AC and provides a regulated DC bus voltage for the motor power output of the drives. When the drives operate as a generator, the TVR 3.1 functions as an inverter and feeds the energy back into the mains.

In the event of a power failure or if the power supply is switched off, the energy regenerated by the braking of the motors will be dissipated by the bleeder resistor in the TVR 3.1.

The TVR's internal power contactor makes it possible to disconnect the drives from the mains.

Electronic power supply

The TVR supplies low voltages to the drive modules via the wire ribbon cable. If there is a mains power failure, electronic voltages are supplied from the DC bus circuit. Therefore, as the drives operate as a generator, the electronics of the drives remain functional.

Drive system monitoring

The TVR 3.1 is equipped with extensive monitoring functions. These communicate with the drive modules via the wire ribbon cable.

The Bb1 contact of the TVR 3.1 is a high priority signal for operation of the drive system. The power contactor cannot be energized until the Bb1 contact is closed.

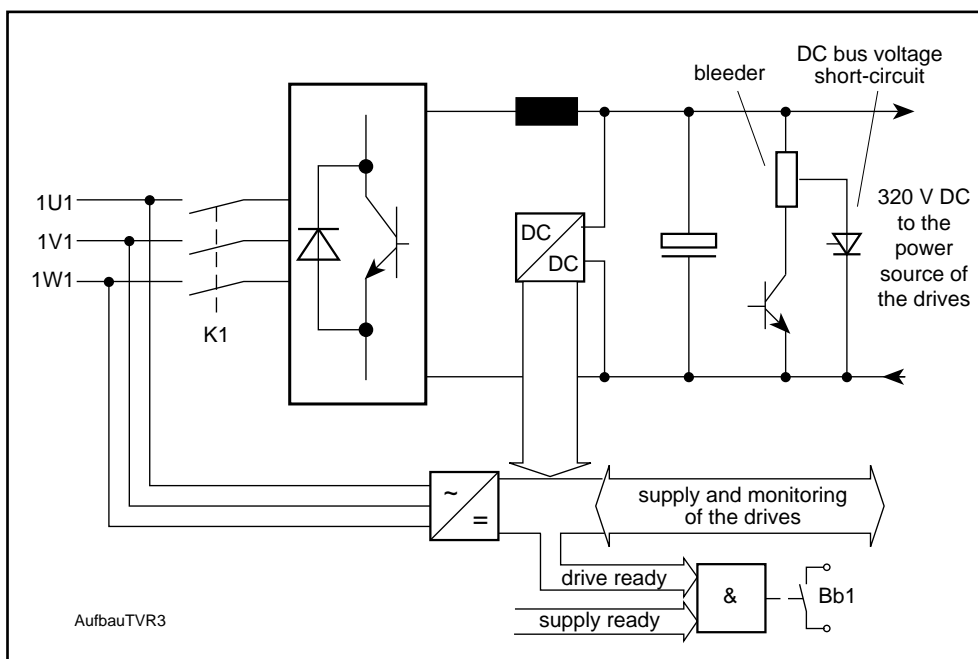

Figure1.2: TVR 3.1 - structure

2. Range of applications

The TVR 3.1 series power supply can deliver up to 12 kW continuous mechanical power to INDRAMAT drives. The TVR 3.1 feeds the regenerated energy created by the braking of the motors back into the mains. The continuous regenerated power can equal up to 10 kW. The TVR 3.1 is particularly suited for those applications with high continuous regeneration power.

The TVD 1 with a 1 kW built-in bleeder resistor is available for applications with smaller continuous regeneration requirements.

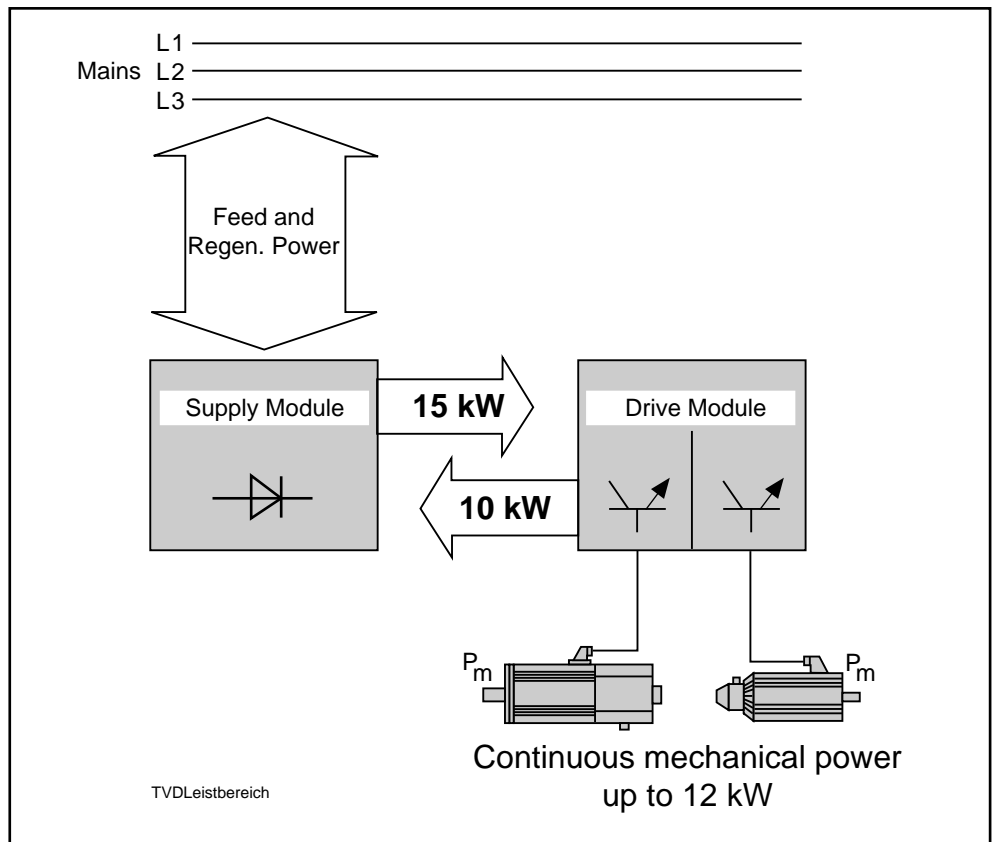

Fig. 2.1: Power range for the TVR 3.1 power supply module

2.1. Power ratings

In the presence of high rotary drive or peak bleeder ratings, the effective performance of the TVR 3.1 can be adapted to the demands of the application using additional components such as the auxiliary bleeder module TBM 1.2.

DC bus and commutation chokes are available as either individual components or built into the NAM 1.2.

(1)		(2)		(3)		(4)	(5)	(6)	TVR 3.1 power supply module additional components		
P_{DC} kW		P_{KB-3} kW		P_{KB-03} kW		P_{BM} kW	W_{max} kWs	P_m kW	NAM 1.2-15 or		auxiliary bleeder module
feed	regen.	feed	regen.	feed	regen.				smoothing choke	commutation choke	
15	10	30	20	45	25	40	100	12	GLD 17	KD 23	---
15	10	30	20	45	25	80	160	12	GLD 17	KD 23	TBM 1.2-40-W1

(1) P_{DC} = DC bus continuous power	(4) P_{BM} = peak bleeder power
(2) P_{KB-3} = DC bus short-term power for 3 secs. (accelerating main drives)	(5) W_{max} = maximum regeneration energy
(3) P_{KB-03} = DC bus peak power for 0.3 secs. (accelerating/braking servo drives)	(6) P_m = mechanical power for > 10 s ON time

Fig. 2.2: Rated power

2.2. Overload Capacity

The TVR can be overloaded for a short period in order to accelerate feed and main drives. The highest possible acceleration power must be considered in the system design and must not be exceeded.

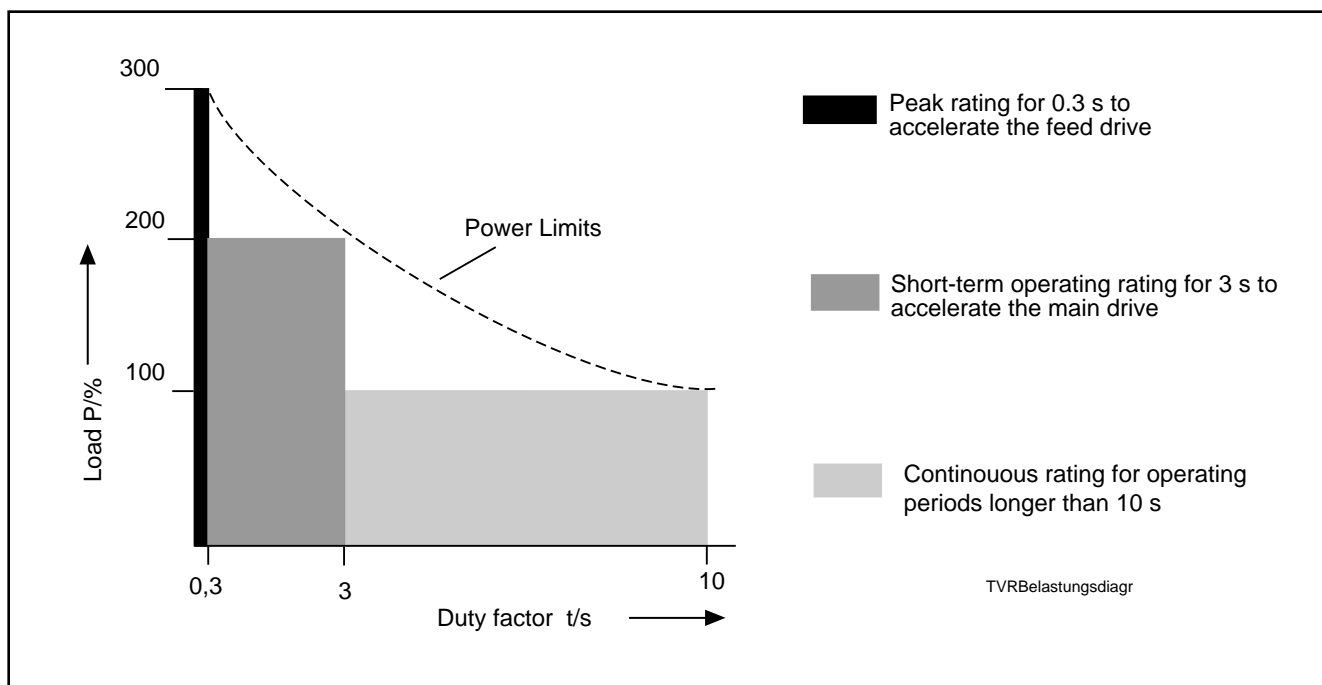

Figure 2.3: Load diagram

2.3. TVR 3.1 - data sheet

Description	Symbol	Unit	TVR 3.1-W015-03
Power supply Input voltage Frequency DC bus voltage Continuous power DC bus circuit (Feed and regeneration)	U_{ACN} f_N U_{DC} P_{DC}	V Hz V kW	3x 380 ... 480 (+/- 10 %) 50 ... 60Hz 320 (+/- 5%) 15/10
DC bus peak power Peak bleeder power Continuous bleeder power	P_{KB-03} P_{BM} P_{BD}	kW kW kW	45 40 Bleeder designed for E-stop only
Maximum regeneration energy with power off	W_{max}	kWs	60
Power losses: Minimum loss Power dissipation	P_V	W	350 50 20 W per kW of DC bus cont. power
Weight TVR 3.1	m	kg	31
Electronic power supply Input voltage Frequency Power consumption under maximum load	U_{AC} f_N S_{el}	V Hz VA	3x 380 ... 480 (+/- 10%) 50 ... 60 500
Control voltage output +24 V Signal voltage +24 V Continuous current \pm 15 V Control voltage +15 V Continuous current -15 V Continuous current	U_L I_{UL} U_M I_{+UM} I_{-UM}	V A V A A	22 ... 26 (2 % ripple) 11 14.9 ... 15.1 (0.1 % ripple) 2.0 2.0
Environmental conditions Permissible ambient temperature for rated specifications Maximum ambient temperature for derated specifications Storage and shipping temperature Altitude without derated performance Permissible humidity according to Humidity classification	T_{amb} $T_{m.amb}$ T_L	$^{\circ}C$ $^{\circ}C$ $^{\circ}C$	+5 ... +45 +55 -30 ... +85 max. 1000 m above sea level F according to DIN 40 040
Contamination level			non-conductive contamination no condensate
Protection category			IP 10 as per DIN 40 050

Fig. 2.4: Data sheet

2.4. Environmental conditions

Increased ambient temperatures

The power ratings and the load capacities of the control voltage supplies given in the data sheet are valid for ambient temperatures +5 to + 45° C. The maximum permissible temperature is +55° C. Thereafter, the output data is derated as shown in the following diagram.

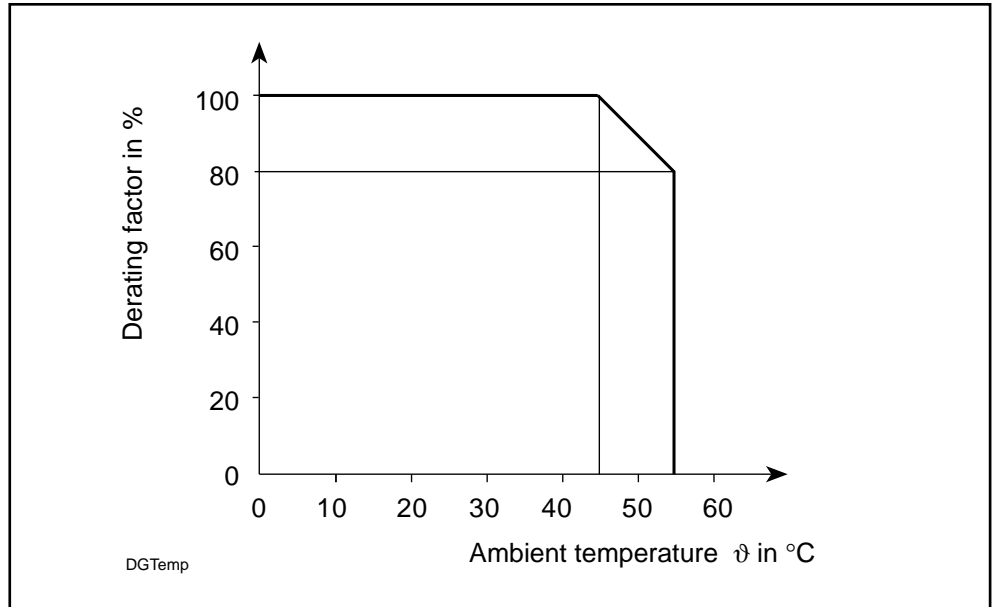

Figure 2.5: Derating power data with increased ambient temperature

Installation altitudes above 1000 m

The power data of the TVR 3.1 is derated, as shown in the following diagram, if the installation altitude is greater than 1000 meters.

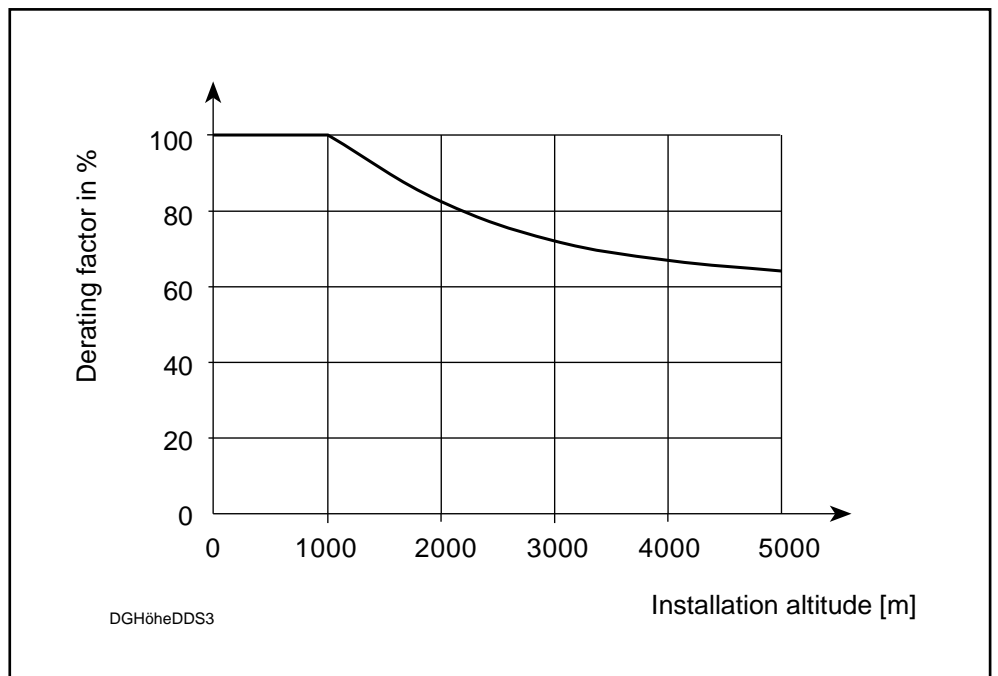

Figure 2.6: Derating power data at altitudes above 1000 meters

2.5. Functional power features

- **High duty factor for the drives possible in regeneration mode**
The energy of the braking motor is fed back into the mains with little loss of power.
- **Direct connection to mains**
The TVR 3.1 can be connected directly to 3 x 380 ... 480V, 50 ... 60 Hz mains without a transformer.
- **Power shutdown by means of an internal contactor**
The contactor which shuts down power for the drives is a component of the TVR 3.1.
- **Internal DC bus short-circuiting**
If a fault develops in the drive's electronics, the servo drives can be braked to a standstill by means of DC bus short-circuiting internal to the power supply.
- **High overload capacity**
Peak power of 45 kW to accelerate motors.
- **Overcurrent protection possible with circuit breakers**
 - Expensive semi-conductor devices are not required.
 - No special fuses for exports.
- **The drive system's reaction to a power failure can be programmed by applying an external link.**
 - Without this signal, drives decelerate at maximum torque.
 - With the link applied, a signal is sent to the NC, and the drives can be guided to standstill under the control of the NC. Expensive tools and workpieces are protected from damage.
- **Regulated DC bus voltage**
No reduction in drive response in the event of mains undervoltage.
- **Soft-start for bridge capacitors**
The inrush current can be ignored when sizing switching components for the power supply. The service life of these components is extended.
- **High loading capacity of the control voltage supplies**
Up to ten drive modules may be connected to the same power supply.
- **Easy to service**
 - Signal lines connected with screw terminals.
 - A numeric display for the extensive diagnostics provides guidance for troubleshooting.

3. Electrical connections – installation guidelines



The TVR 3.1 interconnect found in this documentation is a recommendation of the equipment manufacturer.

The wiring diagram of the machine builder should be used for installation.

3.1. Interconnect diagram

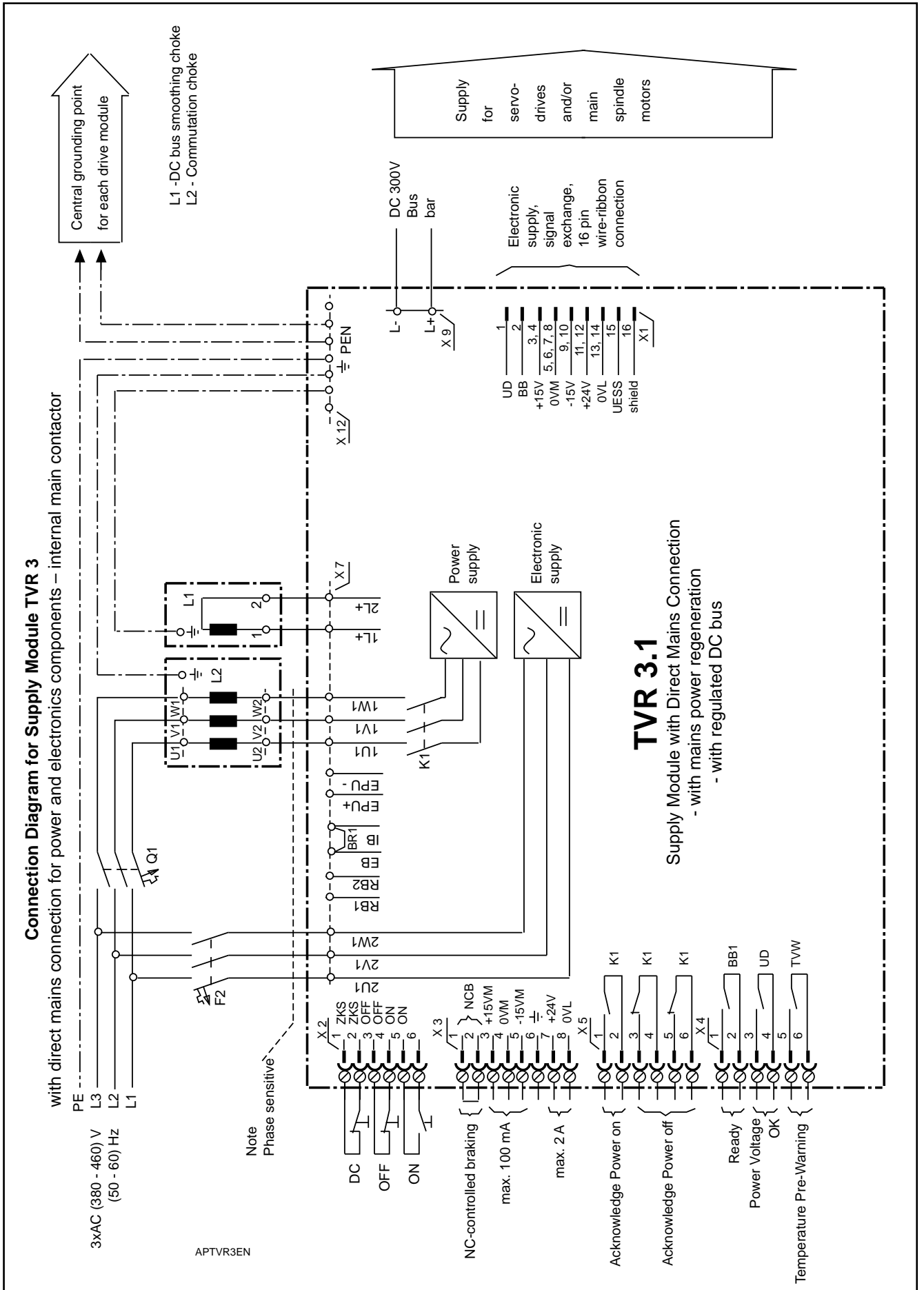

Fig. 3.1: Interconnect diagram for the TVR 3.1 power supply module

3.2. TVR 3.1 interconnect diagram with NAM 1

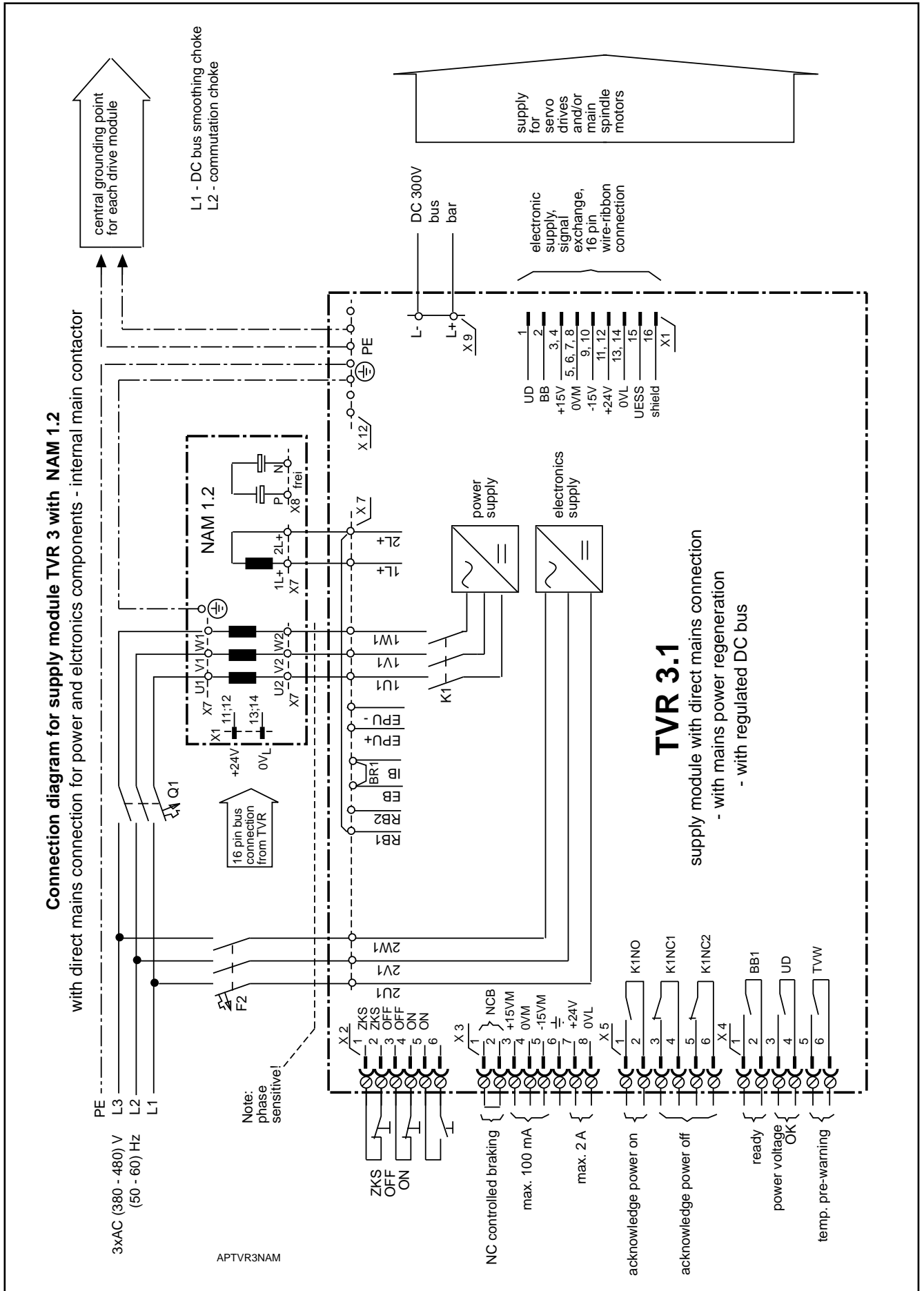

Figure 3.2: Interconnect diagram for the TVR 3.1 power supply module

3.3. Mains connection - high voltage section

Direct connection to mains

The TVR 3.1 can be connected directly to 3 x 380 ... 480V, 50 ... 60Hz mains without a transformer.

The TVR 3.1 supply module, because of its current regulating capability, presents lowest possible mains connect load without reactive loading.

Current regulation in switching power supplies gives rise to mains feedback, the magnitude of which depends on unknown factors (short-circuit power, mains inductance) at the site of the machine's installation.

The TVR must be operated with a commutation choke to eliminate mains reactions.

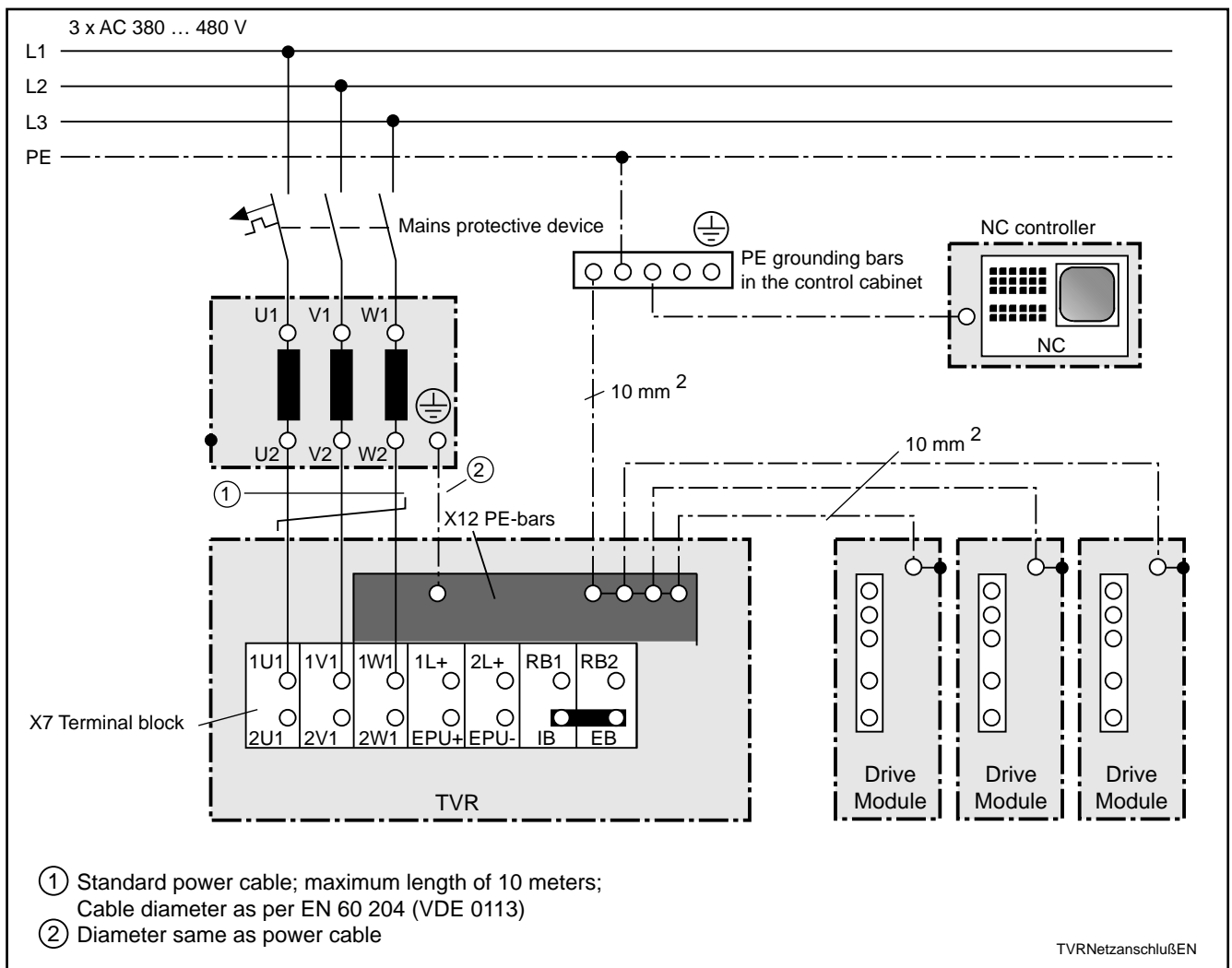

Figure 3.3: TVR high voltage connection to mains

For cross-section dimensions of cable to mains and recommended fuses, see Section 3.3.

Each drive module must be individually connected with a ground wire to the protective earth (PE) busbar on the TVR.



It may be necessary to build an rf interference filter into the mains line when operating modular drives in residential and light industrial areas to maintain the limit values for the transmission of interference.

Mains connection with a transformer A transformer can be used to adapt the voltage, if mains voltage is less than 3 x 380 ... 480VAC.

The inductance (stray inductance) of transformers can vary considerably dependent upon power and type. For this reason, a commutation choke will be necessary when a transformer is used.

Required transformer power:

$$S_{TR} = \frac{P_{DC} \times \sqrt{3} \times U_N}{25,5}$$

S_{Tr} = transformer power in VA
 P_{DC} = continuous DC bus power in W
 U_N = transformer output voltage in V

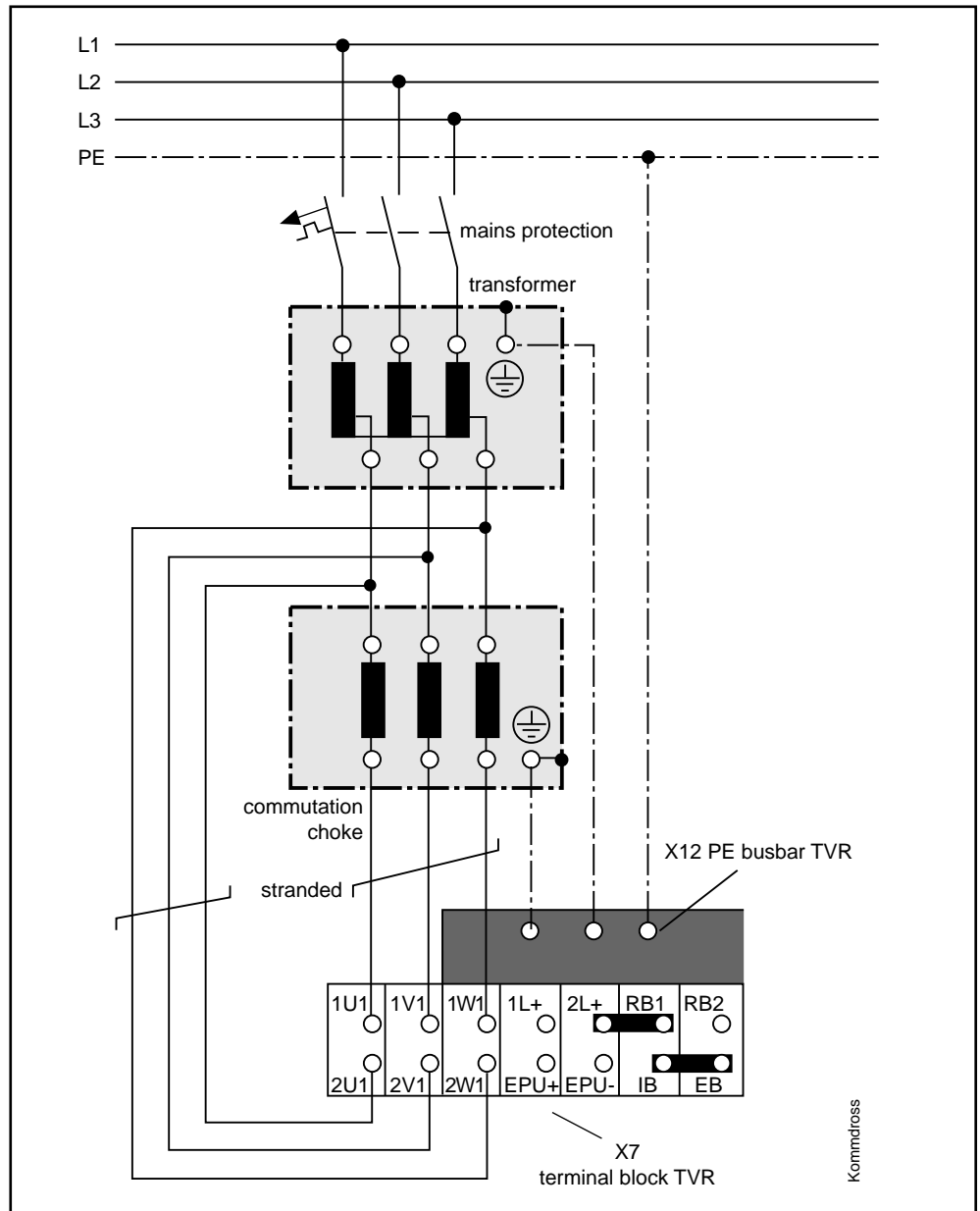

Fig. 3.4: TVR high voltage connection to mains with transformer

3.4. Fuse protection with direct mains connection

If the TVR 3 is connected directly to mains, the power section can be protected by using gL type (time delay, fast response) circuit breakers or fuses.

Maximum fusing

The fuse rating must not exceed 35 A.

The following recommendations are valid when circuit breakers are used for direct connection to mains.

If fuses are used, type gL fuses can be used. Semi-conductor devices are not required. Select fuses according to mains current.

$$I_N = \frac{P_{DC}}{\sqrt{U_N \cdot 25,5}}$$

I_N = mains current in A
 P_{DC} = continuous DC bus power in W
 U_N = mains voltage in V

DC bus power	Connected load at 380V	Mains current		Circuit breakers Siemens type	Current setting	Cross section of mains connect cable ²⁾
		380V	480V			
15 kW	20 kVA	30 A	27 A	3VU1600-.MP00 ¹⁾	30 A	6 mm ²

¹⁾ Max. back-up fuse (gL) per manufacturer: 200A NH with connected load to 500 V
²⁾ Cable cross-section according to EN 60204 - installation type B1, without taking correction factors into consideration.

Figure 3.5: Recommended protection devices

3.5. TVR grounding requirements

Grounded three phase mains

The TVR can be connected to a grounded wye or delta system without potential isolation.

Ungrounded three phase mains

For ungrounded systems, there is increased danger for excessive overvoltage to occur between the phases and the housing. The TVR 3.1 can be made safe against excessive overvoltage,

- if the TVR 3.1 is connected using an isolation transformer
- if the installation is protected with an overvoltage detector.

Connecting the TVR 3.1 by means of an isolation transformer offers the best protection against overvoltage and the greatest operational safety.

- Overvoltages*
- Periodic overvoltage on the TVR 3.1 between a phase (1U1, 1V1, 1W1, 2U1, 2V1, 2W1) and the housing must not exceed 1000V peak-to-peak.
 - According to VDE 0160, non-periodic overvoltages between phases, and between phases at the housing are acceptable for the TVR 3.1.

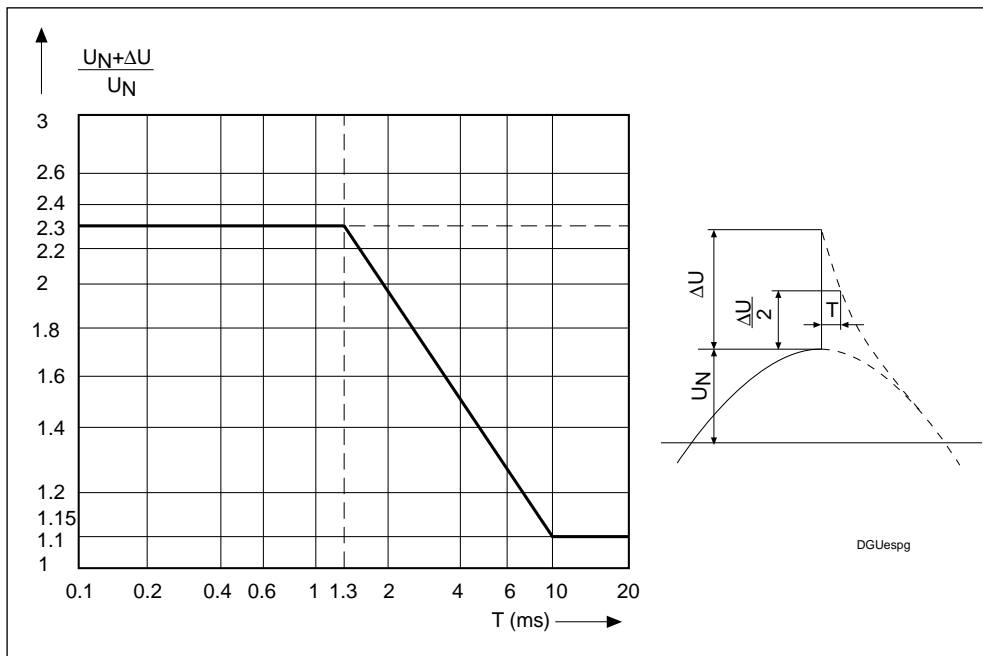

Fig. 3.6: Permissible non-periodic overvoltages as per VDE 0160

The TVR 3.1 can be connected to 3x 380 V.

Therefore, the maximum permissible overvoltage is:

$$480 \text{ V} \times \sqrt{2} \times 2.3 = 1560 \text{ V}$$

3.6. Commutation Choke

The TVR is operated with a KD 23 commutation choke to eliminate mains reactions. For cable dimensions and wiring layout, see Sections 3.2 and 3.3, for power loss, see Section 7, dimension sheet.

3.7. DC bus voltage circuit

Use the busbars found in the electrical connection kit with the drive to connect the drive modules to the DC bus.

Use individual stranded wire cables, with a maximum of one meter length, for longer connections.

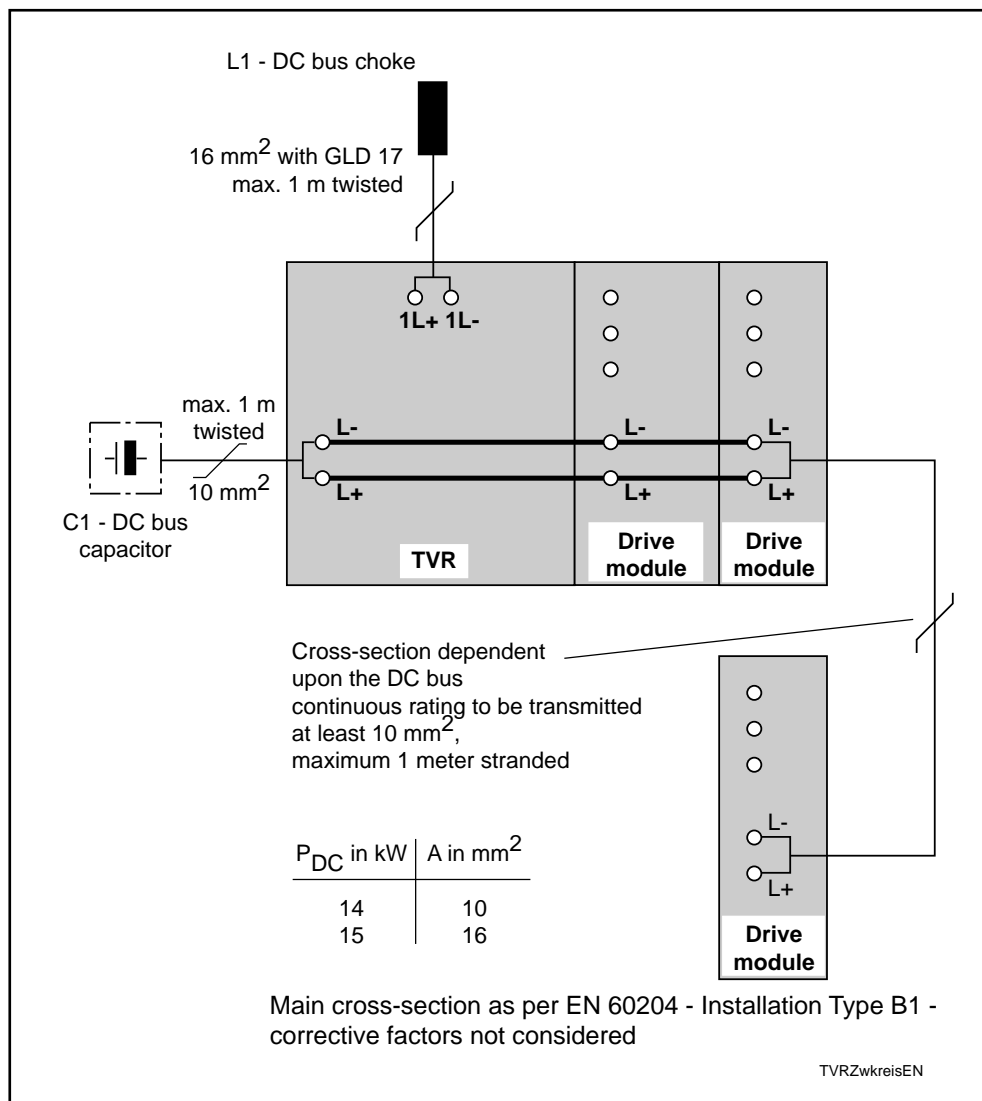

Fig. 3.7: Wiring the DC bus circuit

3.8. DC Bus Choke

The TVR 3.1 must always be operated with a GLD 17 DC bus choke in the „L+“ line.

For cable length and wiring layout, see Section 3.6; for power loss, see Section 7, dimension sheet.

3.9. Adding capacitance to the DC bus

In some applications, the drives are required to perform a return positioning process if there is a power failure or if an E-stop condition occurs. The energy stored in the DC bus can be used to perform this return move. The energy stored in the DC bus can be increased by adding capacitance to the DC bus.

Maximum additional capacitance: $C_{max} = 50 \text{ mF}$

For cable length and wiring layout, see section 3.6.

3.10. Additional bleeder module TBM 1.2

An additional bleeder module, the TBM 1.2, is required if the peak regenerated power of the drives is greater than 40 kW.

Peak regenerated power generally occurs whenever all axes are braked to standstill during an E-stop.



The sum of peak regenerated power from all connected servo drives which are braked simultaneously in extreme cases must not exceed the peak bleeder power capability of the power supply module. If this is not taken into consideration during the system design, the DC bus voltage can rise too high during an Emergency Stop and cause equipment damage.

The combination of the TVR 3.1 and the TBM 1.2 provide the following power rating:

- Peak regenerated power: 80 kW
- Maximum regenerated energy: 160 kWS

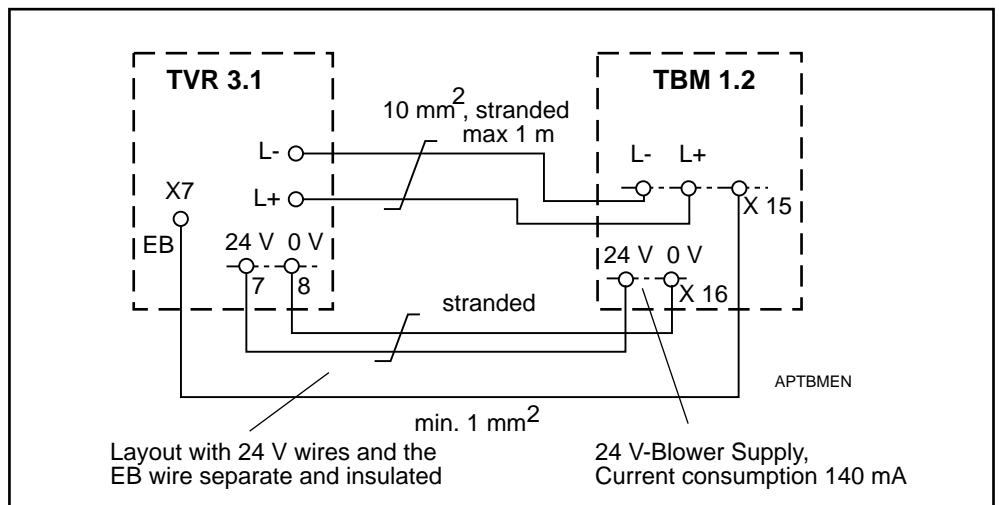

Fig. 3.8: Interconnect for the TBM 1.2 bleeder module

3.11. Electronics and Fan Supply

Electronic supply

Input voltage: 3 x 380 ... 480 VAC, 50 ... 60Hz
 Power requirements: 500 VA (at maximum load)

The high power and electronics line inputs must be in-phase for the TVR to be able to regenerate to mains.

A simple three-phase switch is all that is required to connect the electronics supply to mains. Commercial circuit breakers may be used, for example, Siemens 3VU 1300-0MK00-4 ... 6A

Maximum fuse rating: 10A

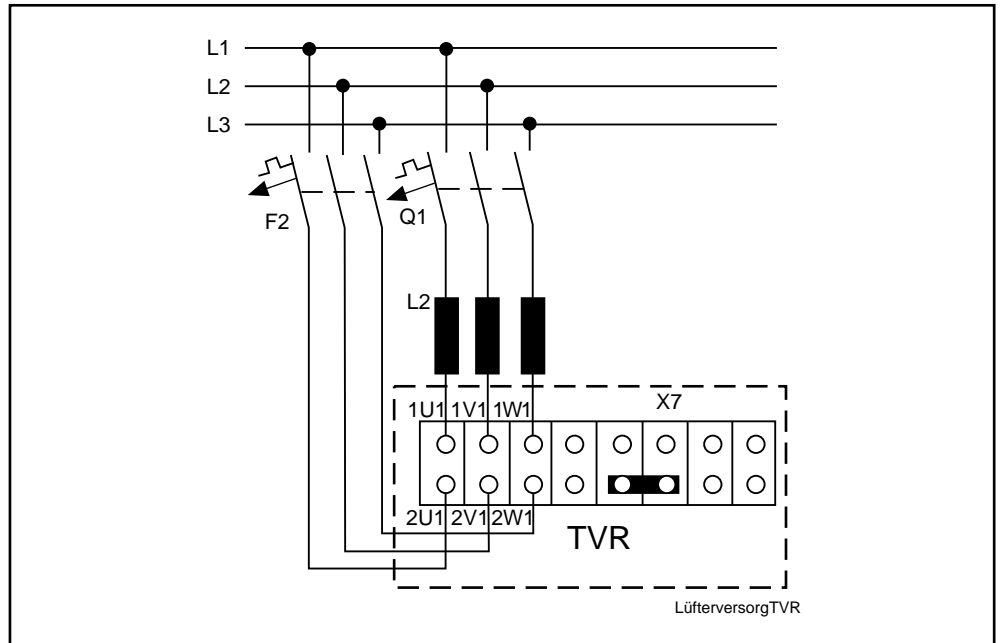

Fig. 3.09: Connections for TVR electronics and fan supply

Fan supply voltage

The TVR 3.1 requires no special connection for the fan supply. If the drive packet contains drive modules requiring 115V or 220V for blowers, connect the input voltage to the drive module nearest the TVR.

The connector for blower voltages must be ordered separately. (Part description: Fan connector plug, part number 219 118)

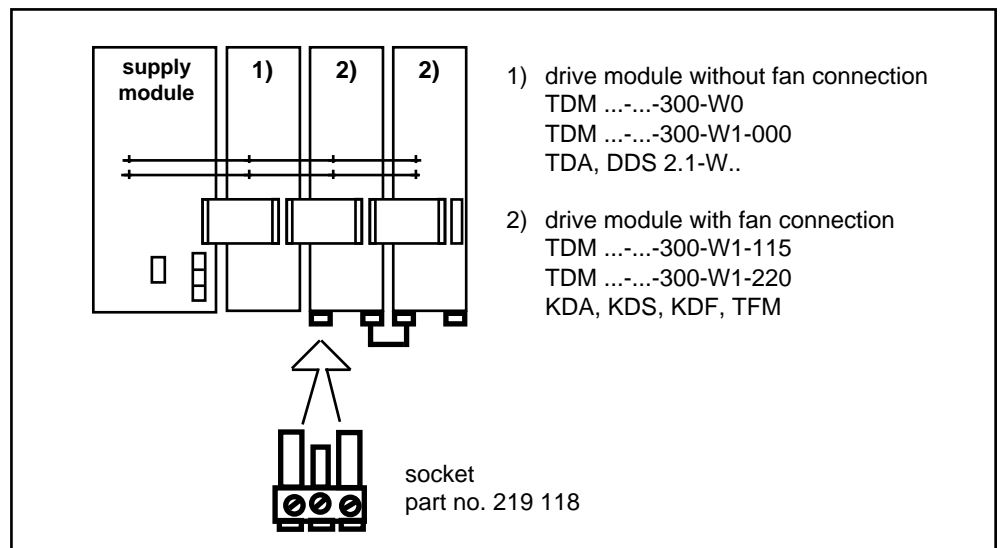

Fig. 3.10: Fan connections for drive modules

3.12. Electronics supply buffer capacitor

Terminal X7/EPU+/EPU-

Connecting cable cross-section 1 mm²

The addition of a buffer capacitor for the electronics supply may be required if the drives are to be braked to standstill under position control in the event of a power failure. A power failure is signalled by the UD output. After this, the NC must have initiated a controlled halt of the drives within 10 ms so that the drive electronics remain functional. If the time until the drives regenerate energy into the DC bus is longer than 10 ms, the user can buffer the electronics supply by means of additional capacitors.

Buffer time	Buffer capacitor (with max. loading of the electronic supply)
20 ms	150 µF
50 ms	270 µF
100 ms	680 µF

Because it requires so little space, an aluminum electrolytic capacitor is recommended.



The voltage between EPU+ and EPU- can be as high as 450 V DC. The capacitor must be designed to support this voltage.

A maximum of 680 F can be connected; if this is exceeded there is a danger of damaging the TVR.

3.13. Electronics supply and signal exchange connections

Terminal connection X1 has two purposes:

- voltage source for drive electronics, and,
- signal exchange between the power supply and the drives.

A wire ribbon cable, with 16 pins, is part of the electrical accessories kit for the drive module.

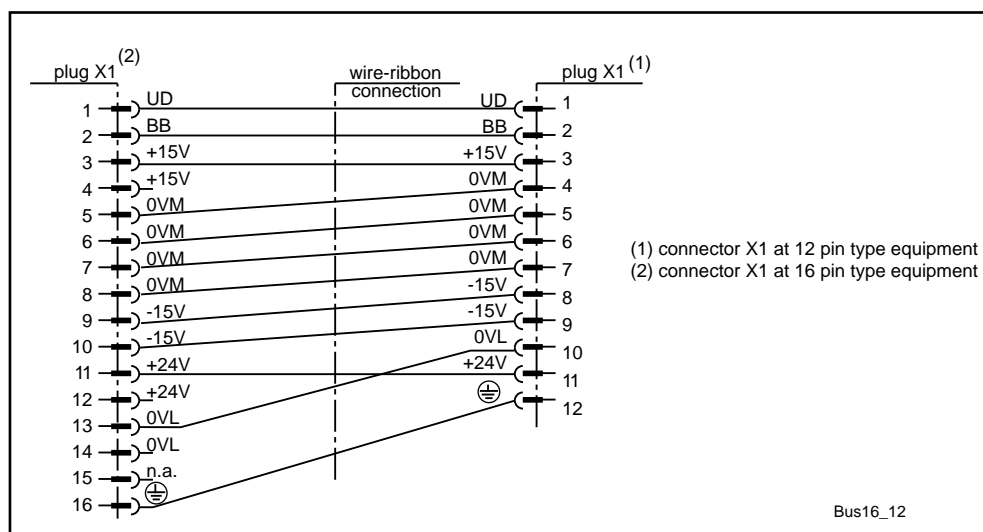

Fig. 3.11: Wire ribbon cable; transition from 16 pin to 12 pin connector

The wire ribbon connection is completed with a terminating plug for verifying the wiring. Without it, the high voltage section of the TVR cannot be powered up. The TVR might possibly be installed in the middle of a drive packet. In this case, it is sufficient if one end of the wire ribbon connection is terminated.

The terminating plug is a part of the electrical accessory kit (E-Kit) of the TVR.

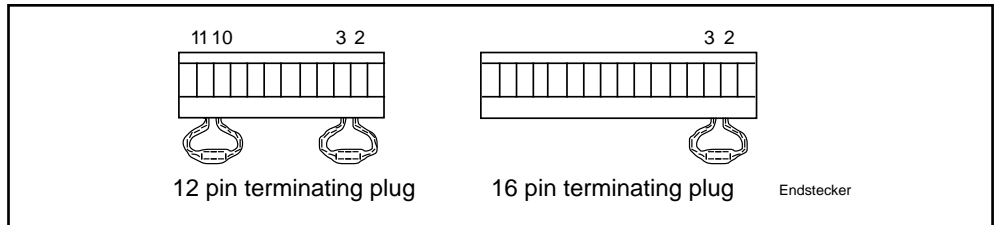

Fig. 3.12: Connector for termination of the wire ribbon connection

3.14. Current limiting protective devices

A current circuit breaker should preferably be used to switch power off in the event of a short-circuit in the housing (fuses, power circuit breaker). If a current operated earth-leakage circuit breaker is absolutely required in a TT (grounded neutral) system because of the size of the grounding resistance, then the following must be considered.

In the case of a switched-mode drive controller, capacitive leakage currents always flow to ground.

The degree of the leakage current is dependent on

- the number of drive controllers used,
- the length of the motor power cable, and,
- the grounding conditions on site.

The leakage current inevitably rises if steps are taken to improve the electromagnetic compatibility of the machine (mains filter, shielded lines). Do **not** use FI type current limiting circuit breakers with leakage currents of less than 0.3 A!



False tripping can occur when switching inductances and capacitances on (interference filters, transformers, contactors, electromagnetic valves). If the plant is equipped with an rf interference filter, then the installation of an isolation transformer will secure it against false tripping .



Commercial pulse-sensitive FI type current limiting circuit breakers (unit designation $\sim\sim\sim$) do not guarantee that electronic equipment with three phase bridge circuit (B6 circuit) is sufficiently protected. The protection of electrical equipment connected to such circuit breakers together with equipment with B6 circuits can be impaired.

Either FI type current limiting circuit breakers which switch off with three phase leakage currents should be used, or an isolation transformer should be placed in the mains supply line.

If isolation transformers are used then the overcurrent protective devices must be tuned to the impedance of the ground fault loop so that there is an immediate tripping in the event of a fault. Connect the wye point of the secondary windings to the protective conductor of the machine.

3.15. Control cabinet testing



No voltages other than those specified in the data sheet or in the interface notes should be connected.

Prior to a high voltage test of the control cabinet, disconnect all connections from the TVR.

3.16. Mounting the TVR 3.1 in the control cabinet

Installation requirements

The power supply module and its associated drive modules are designed to be installed in a control cabinet or a closed housing. They correspond to protection classification IP 10 as per DIN 40 050.

The unit is protected from penetration of solid, foreign matter with a diameter greater than 50 mm.

The unit is not protected against

- the admission of water, or,
- intentional access, for example, a touch of the hand. However, it does keep flat surfaces away.

Arranging the drives

Arrange the drives so that the one requiring the greatest power and current is as near as possible to the power supply.

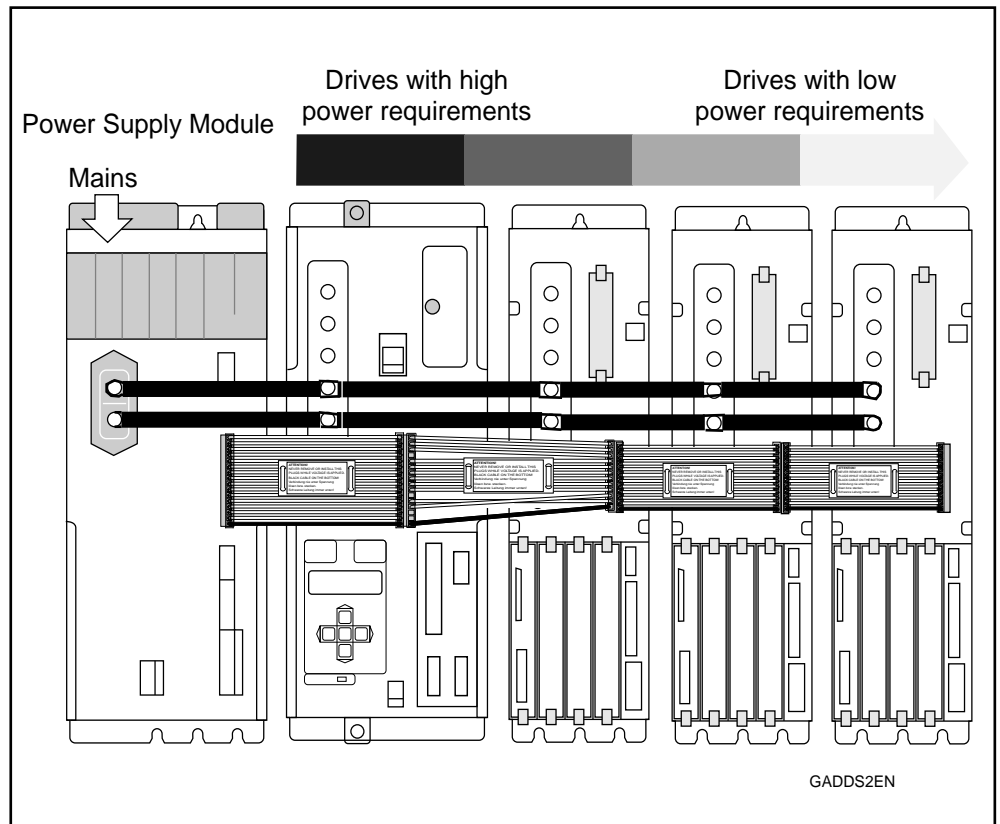

Fig. 3.13: Preferred arrangement of units in the control cabinet

Spacing dimensions in the control cabinet

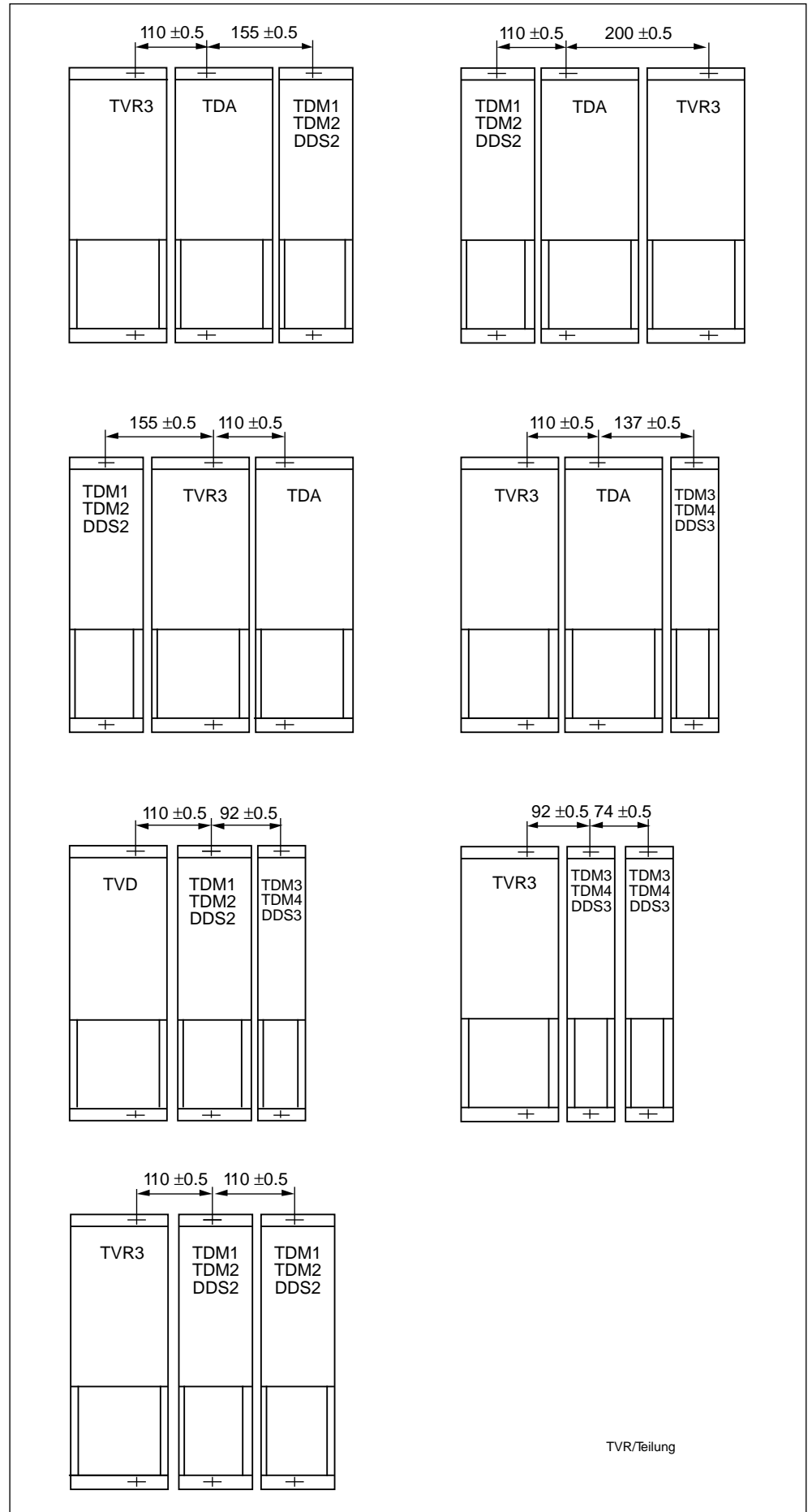

Fig. 3.14: Spacing dimensions in the control cabinet

3.17. Heat loss inside the control cabinet

Basic losses in the TVR 3.1 occur as a result of the generation of signal voltages and high voltage power.

Basic losses Basic losses equal 50 W.

Losses of high voltage section 20 W per kW of DC bus continuous power.

3.18. Bleeder safety clearance inside the control cabinet

The bleeder resistor in the TVR 3.1 is hot after power is shut down. Flammable materials such as cables and cable channels must be kept at a distance of at least 100 mm above and 40 mm to the side and to the front of the bleeder resistor.

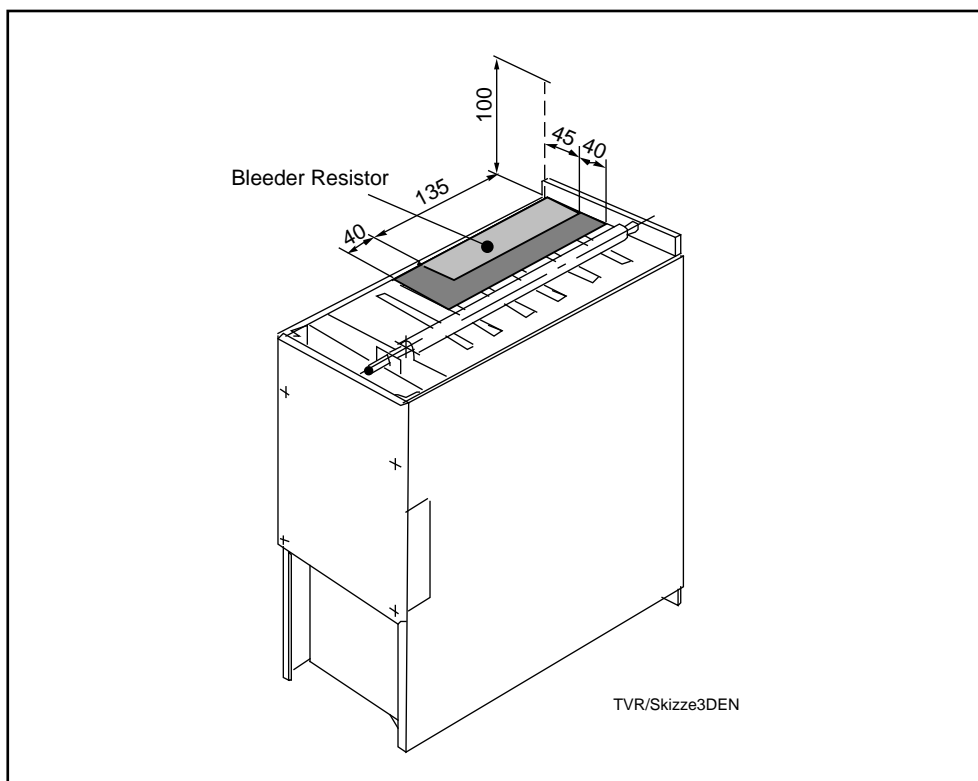

Figure 3.15: Bleeder clearance in the control cabinet

3.19. Front view of the TVR 3.1

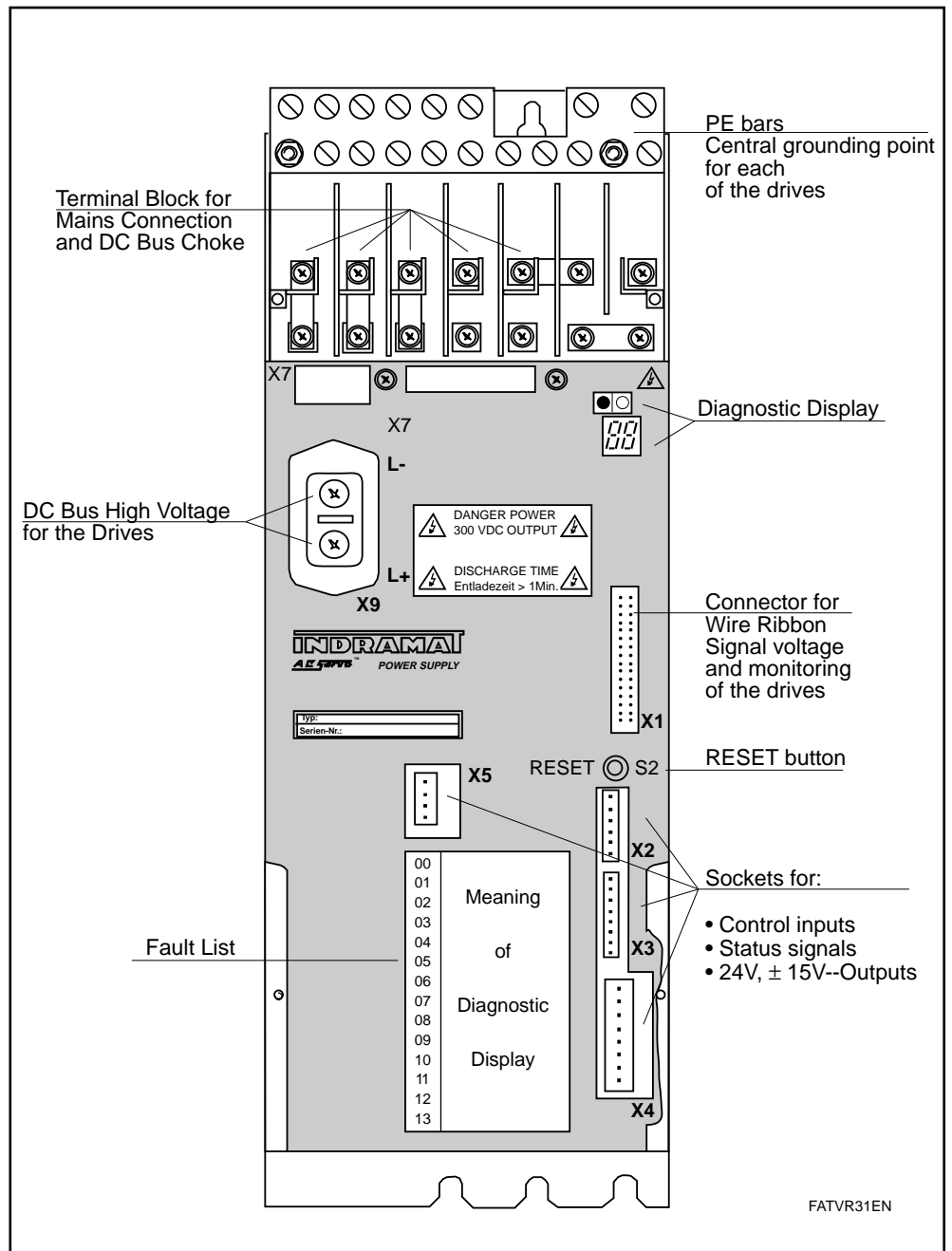

Figure 3.16: Front view of the TVR 3.1 with accessories

4. TVR 3.1 interconnections

The interconnections for mains and the DC bus of the TVR recommended by INDRAMAT illustrate the operating principles of the unit. This section outlines several interconnect configurations. Just which configuration is selected depends on the functions and the sequence of actions required for the entire machine and is the responsibility of the machine builder.

4.1. Options

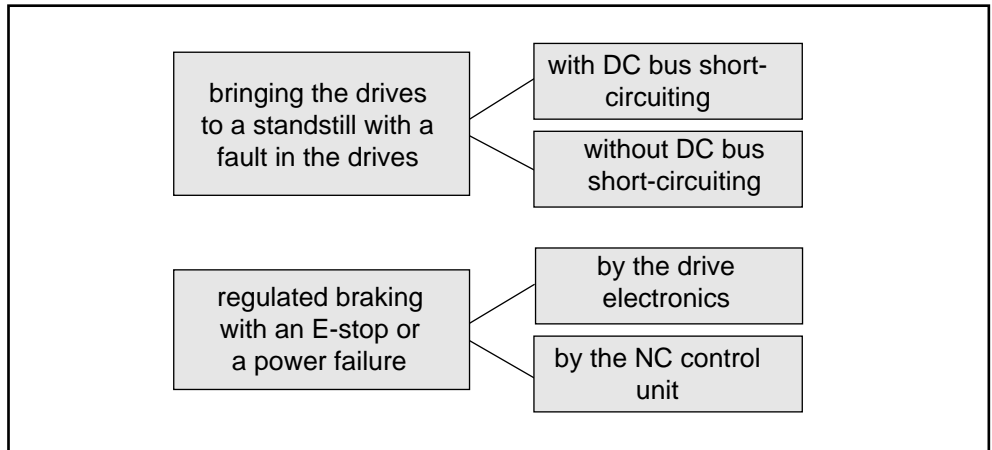

Figure 4.1: Possible control interconnections

Stopping the drives with or without DC Bus short-circuiting

The DC bus is short-circuited for braking the drives to a standstill as an additional safety precaution if there is ever a fault in the drive electronics.

With DC bus short-circuiting, synchronous motors are always braked to a standstill regardless of whether the drive electronics are functional or not.

Asynchronous motors cannot be braked if the DC bus is short-circuited!

Without DC bus short-circuiting, operating drives can be braked with maximum torque.

Regulated braking of the drives by the drive electronics or position-controlled by the NC control in an E-stop or due to mains failure

Drives are generally brought to a standstill by the drive control with an E-stop or a mains failure.

In the event of an E-stop or if the drive-internal monitors are tripped, then drive control switches to zero command value and there is a regulated braking of the drives at maximum torque.

In some cases (e.g., electronically coupled tooth gear machines) it may be necessary for the CNC to bring the drives to a standstill in an E-stop situation or a mains failure.

There is then a regulated braking of the drives by the NC control unit with an E-stop or if the drive-internal monitors are tripped.

4.2. TVR interconnect with DC bus short-circuiting

Application If modular synchronous motors are used.

This achieves excellent safety at low cost. The monitor circuits built into the drive system is here most effectively used.

Typical application:

- the TVR is supplying feed drives only
- asynchronous main drives and feed drives are operated from the same TVR

Features It is possible to brake INDRAMAT AC drives even when power is off. In general, if there is an E-stop condition, power is **immediately switched off**. The energy from the moving drives is converted to heat dissipated in the bleeder resistor of the power supply.

With DC bus short-circuiting, synchronous motors are always braked to standstill regardless whether the drive electronics are operational or not. DC bus short-circuiting occurs **only if there is a fault** in a drive. Therefore, if the E-Stop button is pressed, asynchronous drives are also braked.

If there is an E-Stop or one of the monitor circuits of the TVR is tripped, for example, power failure, the drives are braked at maximum torque under **drive regulation**.



The NCB link on the TVR (X3/1 - X3/2) must not be jumpered.

Mode of operation

When the E-Stop button is pressed, the main contactor in the TVR 3.1 drops out immediately. The drive enable signal of the drives is dropped by means of an auxiliary contact of the main contactor. This leads to a drive-internal switching of the velocity command to zero in all drives in the drive packet. All drives are braked under control.

A drive fault signal to the TVR 3.1 (Bb1 contact), a fault signal from the NC (servo fault), or an overtravel signal from the overtravel limit switch cause the main contactor to be switched off and DC bus short-circuiting to be applied.

4. TVR Interconnection Diagrams

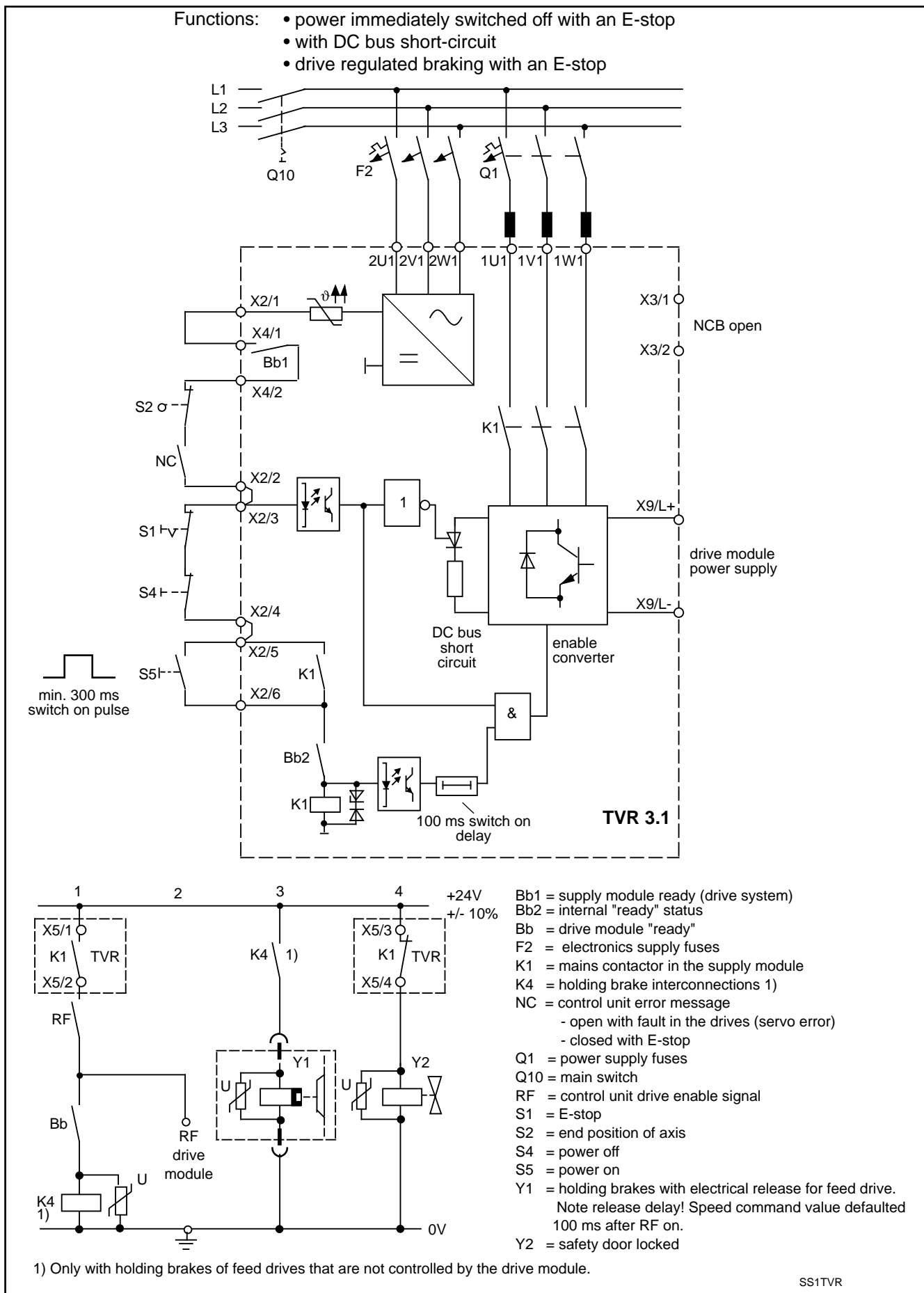

Figure 4.2: Controlling the TVR 3.1 with DC bus short-circuiting

4.3. TVR interconnect with E-stop relay with DC bus short-circuiting

Application If modular synchronous motors are used.

Excellent safety at low cost is achieved. The monitor circuits built into the drive system is used most effectively.

Typical applications:

- in larger plants where monitoring or numerous E-stop switches are required,
- if the TVR is supplying feed drives only, or,
- if asynchronous and synchronous drives are operated from the same TVR.

Features It is possible to brake INDRAMAT AC drives even when power is off. In general, if there is an E-Stop condition, power is **immediately switched off**. The energy from the moving drives is converted to heat dissipated in the bleeder resistor of the power supply.

DC bus short-circuiting always brakes synchronous motors to a controlled standstill regardless of whether the drive electronics are still functioning or not. DC bus is short-circuited only if there is **a fault in the drives**. If the E-stop relay is switched off, then asynchronous main drives can be braked as well.

If there is an E-Stop or one of the monitor circuits of the TVR is tripped, for example, power failure, the drives are braked at maximum torque under **drive regulation**.



The NCB link on the TVR (X3/1 - X3/2) must not be jumpered.

Mode of Operation When the E-Stop button is pressed, the main contactor in the TVR 3.1 drops out immediately. The drive enable signal of the drives is dropped by means of an auxiliary contact of the main contactor. This leads to a drive-internal switching of the velocity command to zero in all drives in the drive packet. All drives are braked under control.

A drive fault signal to the TVR 3.1 (Bb1 contact), a fault signal from the NC (servo fault), or an overtravel signal from the overtravel limit switch cause the main contactor to be switched off and DC bus short-circuiting to be applied.

4. TVR Interconnection Diagram

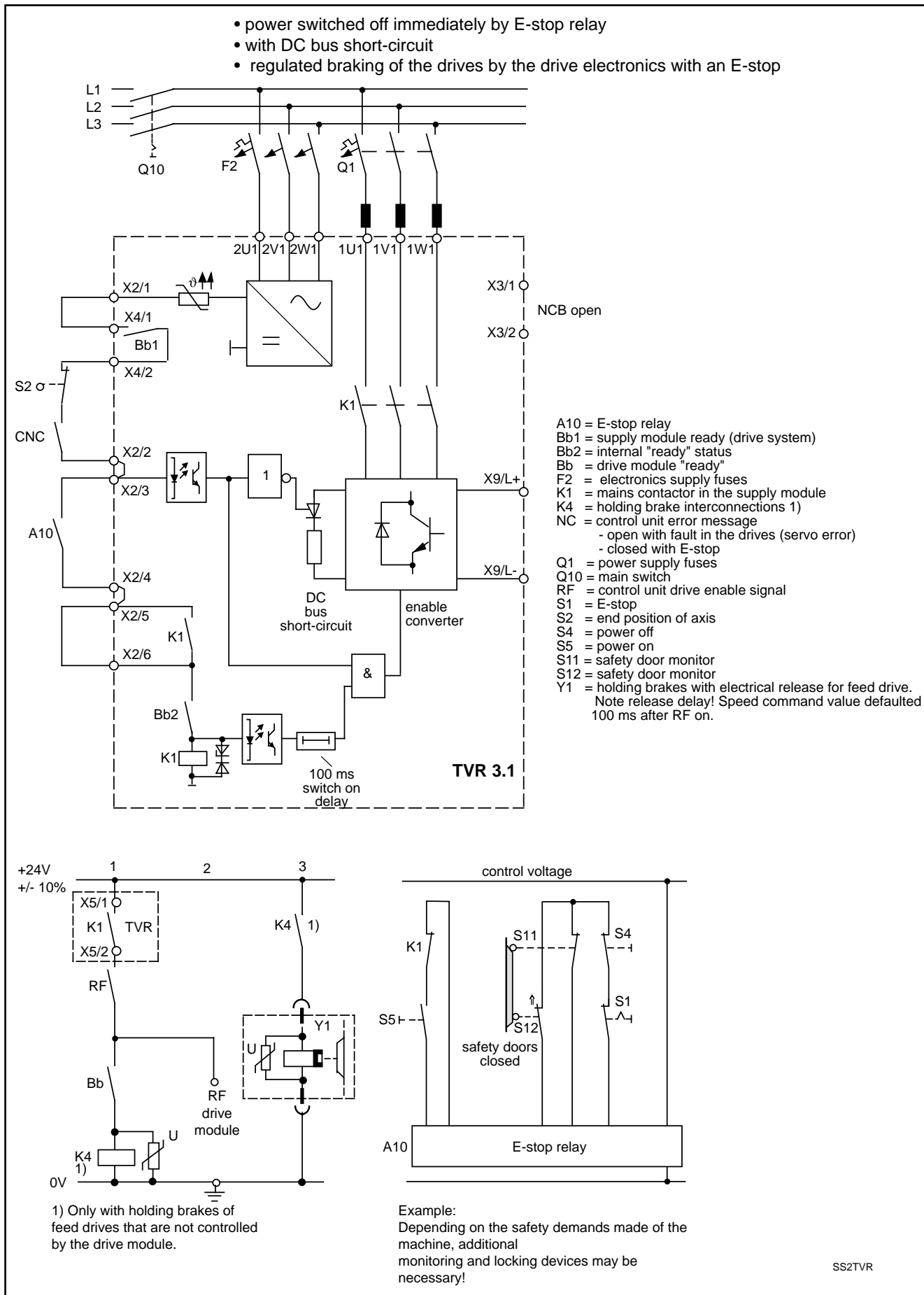

Fig. 4.3: TVR 3.1 interconnect with DC bus short-circuiting

4.4. TVR interconnect without DC bus short-circuiting

Application If the uncontrolled coasting of the drives cannot damage the plant.

Typical applications:

- TVR 3.1 supplying asynchronous drive only
- if end-stops of feed axes are sufficiently damped

Features It is possible to brake INDRAMAT AC drives even when power is off. In general, if there is an E-Stop condition, power is **immediately switched off**. The energy from the moving drives is converted to heat dissipated in the bleeder resistor of the power supply.

The DC bus is **not short-circuited**. In the case of asynchronous drives, if there is a fault in drive electronics, the DC bus is short-circuited and can provide no braking power. If the DC bus is short-circuited, asynchronous drives can no longer be braked under drive control.

With an E-Stop or if one of the monitor circuits of the TVR is tripped, e.g., power failure, the drives are braked at maximum torque under **drive regulation**.



The NCB link on the TVR (X3/1 - X3/2) must not be jumpered.

Mode of operation

When the E-Stop button is pressed, the main contactor in the TVR 3.1 drops out immediately. The drive enable signal of the drives is dropped by means of an auxiliary contact of the main contactor. This leads to a drive-internal switching of the velocity command to zero in all drives in the drive packet. All drives are braked under control.



If there is a fault in the drive system electronics, the drives coast without control. Therefore, DC bus short-circuiting can only be omitted if uncontrolled coasting will not damage the equipment. As an alternative, motors with mechanical brakes can be installed.

4. TVR Interconnection Diagram

- power immediately switched off with an E-stop
- without DC bus short-circuit
- position controlled braking of the drives by the NC control unit with an E-stop

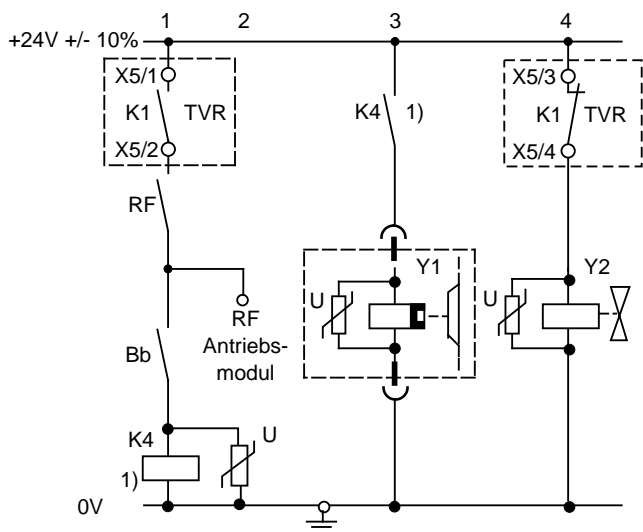
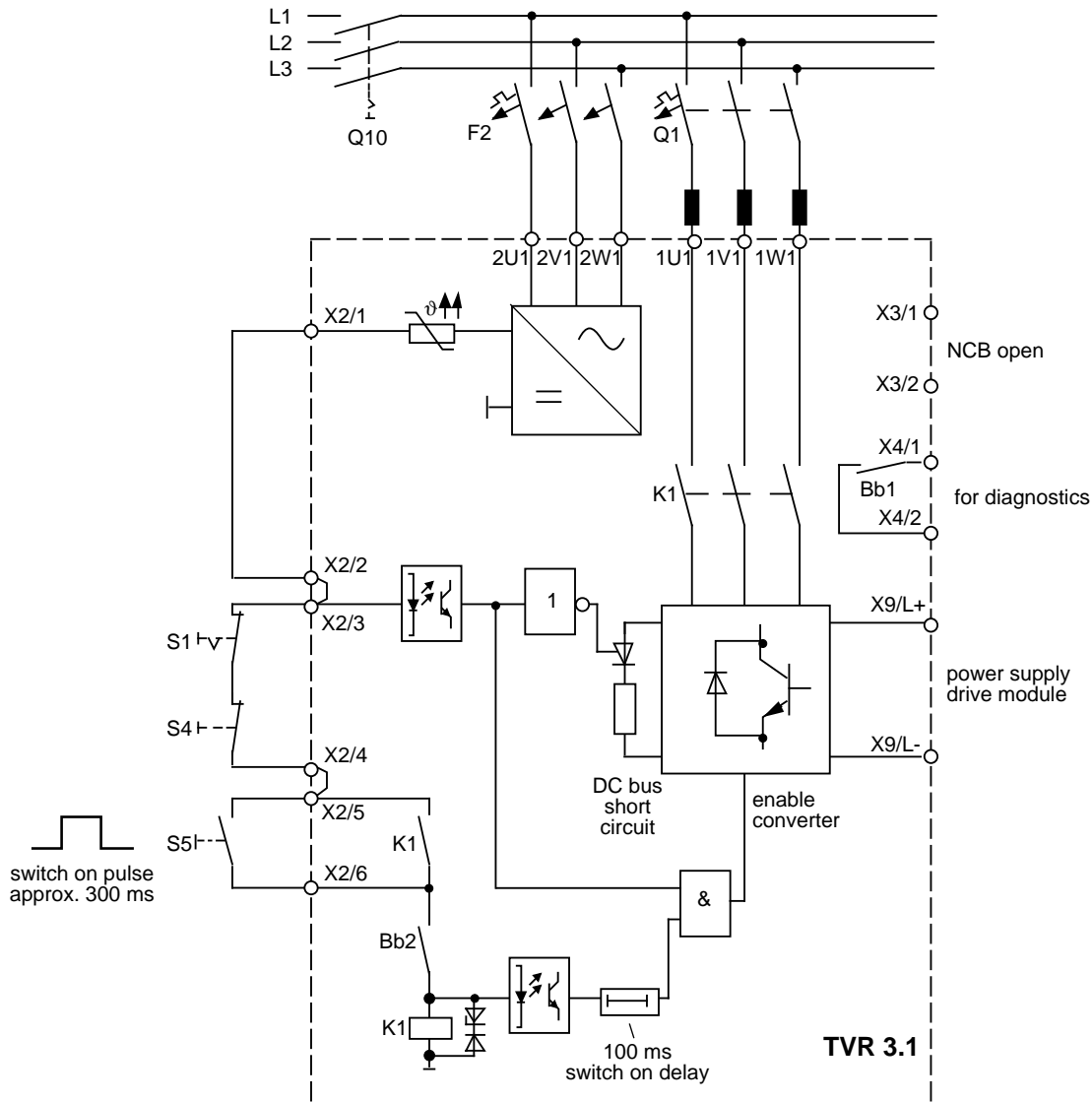

- Bb1 = supply module ready (drive system)
- Bb2 = internal "ready" status
- Bb = drive module "ready"
- F2 = electronics supply fuses
- K1 = mains contactor in the supply module
- K4 = holding brake interconnections 1)
- Q1 = power supply fuses
- Q10 = main switch
- RF = control unit drive enable signal
- S1 = E-stop
- S4 = power off
- S5 = power on
- Y1 = holding brakes with electrical release for feed drive.
Note release delay! Speed command value defaulted
100 ms after RF on.
- Y2 = safety door locked

1) Only with holding brakes of feed drives that are not controlled by the drive module.

SSTVR/3

Fig. 4.4: TVR 3.1 interconnect without DC bus short-circuiting

4.5. TVR interconnect for a position-controlled braking of the drives

Application Drives which are coupled electronically as if by gearboxes under the control of an NC cannot normally accept an angular positioning error in the event of a power failure.

Features It is possible to brake INDRAMAT AC drives even when power is off. In general, if there is an E-Stop condition, power is **immediately switched off**. The energy from the moving drives is converted to heat dissipated in the bleeder resistor of the power supply.

The DC bus is **not short-circuited** so that energy is available for position regulated stopping of the drives.

During E-Stop or if one of the monitor circuits of the TVR 3.1, for example, power failure, is tripped, the drives will be brought to standstill under **position control** through the NC.

The energy stored in or regenerated to the DC bus circuit must be greater than the energy required to excite the asynchronous machines or for return movements.



The NCB link on the TVR (X3/1 - X3/2) must be jumpered. The enable signal to the drives must not drop out via the main contactor.

Mode of operation When the E-Stop chain opens, the main contactor in the TVR drops out immediately. The NC must bring the drives to a stop under position control.



A faulty power supply is not signalled to the drives when the NCB link is installed. The superordinated NC does, in any case, bring the drives to a standstill. This means that the superordinated NC absolutely monitors the UD contact and stops the drives if the contact opens. Otherwise, uncontrolled coasting of the drives is to be expected if power from the power supply drops out.

4. TVR Interconnection Diagrams

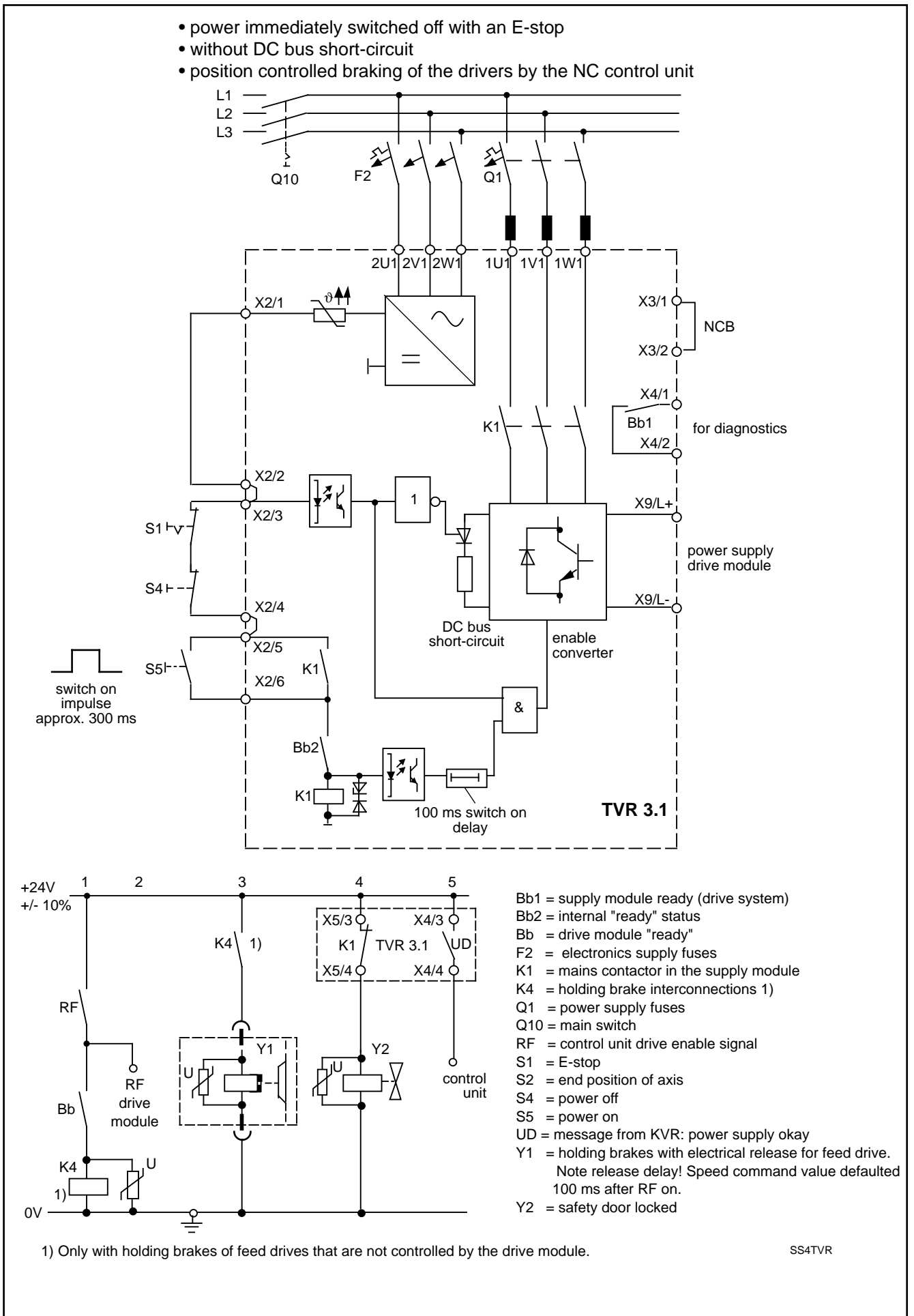

Fig. 4.5: TVR 3.1 interconnect for braking under position regulation

5. Terminal descriptions

5.1. DC bus short-circuiting

Terminal X2/1 - X2/2

DC bus input Voltage: 24 V DC Current consumption: 500 mA

Input	open	closed
Operating status	power off, DC bus short-circuiting closed	power on, DC bus short-circuiting closed

The main power contactor in the TVR can be pulled in only if the ZKS input is closed. The DC bus is short-circuited if the ZKS input is opened. This is an additional safety feature for braking drives to a standstill in the event of a fault in drive electronics.

5.2. Power OFF

Terminal X2/3 - X2/4

OFF input Voltage: 24 V DC Current consumption: 500 mA

Input	open	closed
Operating status	power off	power on

The main power contactor in the TVR can be pulled in only if the OFF input is closed. If the OFF input is opened, for example during E-Stop, the main power contactor in the TVR opens immediately.

5.3. Power ON

Terminal X2/5 - X2/6

ON input Voltage: 24 V DC Current consumption: 500 mA

Input	open	open or closed closed when latched
Operating status	power off	power on

If the ZKS and OFF inputs are closed and the drive-ready signal internal to the unit is present, closing the ON input will cause the TVR main contactor to pull in. Next, the main contactor is latched on. The ON signal is a pulse and must be held high for at least 300 ms.

5.4. Stopping the drives in an E- Stop or a power failure

NCB link Input – terminals X3/1 - X3/2

Jumper	open	closed
controlled braking during E-stop or power failure	by means of drive electronics	under control of the NC

If the NCB link is open or not jumpered, a power failure or a drive fault in the drive system is signalled to all the drives. The drives are braked at maximum torque. In addition, if there is a drive fault, the internal enable signal of the TVR is dropped which leads to shutdown of the power supply.

In some applications, electronically coupled gear cutting machines, for example, the drives have to be braked position controlled through the NC if there is an E-stop or a power failure.



Do not use the NCB link for digital drives with SERCOS interface. Position-controlled braking is done without the NCB link by programming the fault reaction directly into the drive. The NCB link prevents signalling of a faulty power supply to the drive.

With NCB jumpered, the following faults are not signaled to the drives:

- faulty power supply
 - mains power failure/ missing phase
 - DC bus voltage lower than 200 V
- drive faults:
 - an open in the wire-ribbon connection or missing termination connector
 - low-voltage fault (+24VL/±15VM)
 - overcurrent in the TVR high-voltage section
 - bleeder overload
 - overtemperature in the TVR heatsink

Because these monitor circuits are not tripped, the drives can be braked to standstill under position control if there is a power failure. The power regenerated during braking must be greater than the power consumption of the TVR.

The power supply of the TVR 3.1 is always switched off by the internal "ready" signal in the presence of a drive fault.



With the NCB link closed or jumpered, fault messages are suppressed. Therefore, the master controller (NC or PLC, etc.) must ensure that the drives are brought to standstill. This means that the master controller must evaluate the UD contact and stop the drives when this contact opens. Otherwise, uncontrolled coasting of the drives is to be expected if power to the TVR is cut off.

5.5. Signal voltages

Signal voltages can be accessed on terminal strip X3. These terminals are designed for test and measurement purposes. If these voltages are used exterior to the TVR, ensure that no noise or interference is coupled in (short-circuits, shielded leads, etc.).

The signal voltage outputs are short-circuit protected. To prevent damage to the drives, the maximum permissible loading must not be exceeded.

X3/3	+15VM	Electronic voltage max. 100 mA
X3/4	0VM	Reference potential for ± 15 VM
X3/5	-15VM	Electronic voltage max. 100 mA
X3/6	GROUND	Shielding
X3/7	+24VL	Signal voltage maximum 2 A
X3/8	0VL	Reference potential for +24VL

5.6. "Ready" status

Bb1 Output Potential free contact – Terminal X4/1 - X4/2
Max. Load.: DC 24 V/1 A

Status type	Relay de-energized	Fault	Ready
Output	open	open	closed

The Bb1 contact of the TVR is very important and has special significance. The Bb1 contact signals whether the drive packet is ready for the application of high voltage to the drives. The TVR's internal interlocks will not permit the main contactor to pull in until Bb1 is closed.

If there is a fault, the main contactor drops out and the Bb1 contact opens. If Bb1 opens, controlled braking of the drives is no longer assured. Therefore it is used to trigger DC bus short-circuiting.

Bb1 closes when power for electronics is applied to terminal block X7/2U1, 2V1, 2W1 and there is no fault in the drive packet.

Bb1 opens for the following faults:

- tachometer fault
- overtemperature in a drive
- overcurrent in a drive module
- signal voltage fault (± 15 VM, +24VL)
- an open in the wire-ribbon connection or missing wire-ribbon termination
- TVR heatsink temperature too high
- overcurrent in the TVR high voltage section
- overvoltage
- bleeder overload

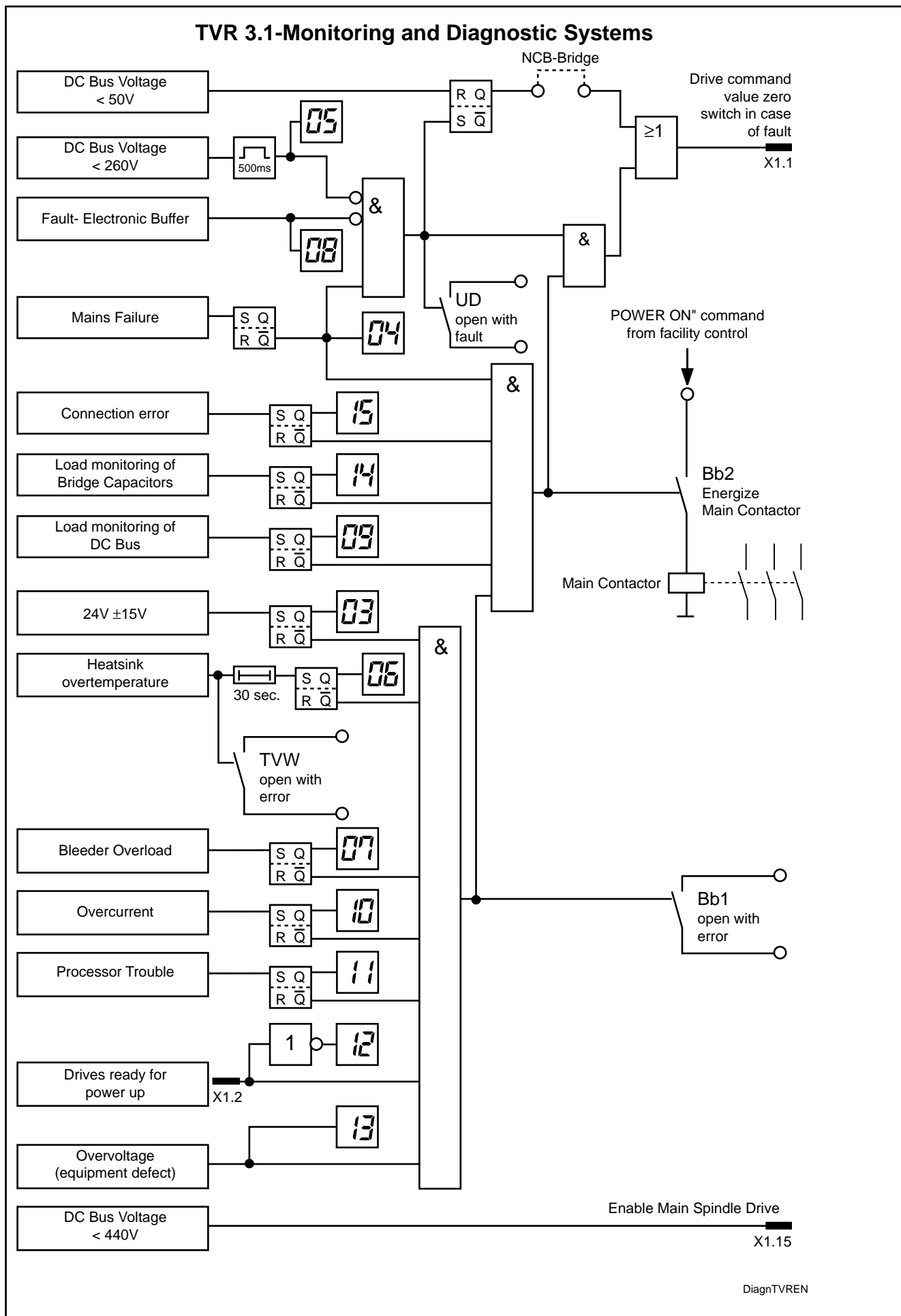

Figure 5.1: TVR 3.1 monitoring and diagnostic systems

5.7. Power OK

UD output Potential free contact – terminals X4/3 – X4/4

Maximum load.: DC 24 V/1 A

Status type	Relay de-energized	Fault	Power OK
Output	open	open	closed

The UD contact acknowledges proper operation of the power system.

UD opens for the following faults:

- mains power failure/ missing phase
- DC bus voltage lower than 200 V

The reaction of the drive system to these faults depends on the NCB link (see section 5.4).

If NC-controlled braking is required, the drives must be stopped by the master controller when the UD contact opens.

5.8. Temperature pre-warning

TVW output Potential free contact – terminals X4/5 – X4/6

Maximum load: DC 24 V/1 A

Status type	Relay de-energized	Temperature too high	Temperature is within permissible limits
output	open	open	closed

The TVW temperature pre-warning contact opens when the temperature of the heatsink of the TVR is too high. After 30 seconds, the TVR main contactor drops out, interrupting power, and the Bb1 contact opens.

The reaction of the drive system to this fault depends on the NCB link. (see section 5.4).

If NC-controlled braking is required, the drives must be stopped within 30 seconds if a temperature pre-warning contact in the TVR or one of the drive modules opens.

5.9. TVR mains contactor energized

K1NO Output Potential free contact – Terminals X5/1 – X5/2

Maximum load: DC 24 V/10 A or AC 220 V/6 A

Status type	contactor de-energized	contactor energized
output	open	closed

The K1NO output can be interrogated to see if the mains contactor is energized. The closed status of K1NO can be used as a condition for the application of the enable signal to the drives. (Exception: see section 4.4).

5.10. TVR mains contactor de-energized

K1NO and K1NC2 output Potential free contact – terminals X5/ – X5/4 und X5/5 – X5/6
Maximum load: DC 24 V/10 A / AC 220 V/6 A

Status type	contactor de-energized	contactor energized
output	open	closed

Outputs K1NC1 and K1NC2 can be interrogated to see if the mains contactor has dropped out. For example, it can be used as a condition for enabling door interlocks.

6. Troubleshooting

Long hours spent troubleshooting and repairing drive components on the machine are unacceptable because of production downtime.

INDRAMAT AC drive components can easily be replaced as entire units with no adjustment required because of their construction.

Therefore, whenever there is a fault, servicing is reduced to localizing the problem to the motor, the power supply, or the drive module. Then simply replace the faulty component.

6.1. Localizing the fault

Faulty drive motions can be caused by interactions of various components: NC, power supply-drive modules, mechanics, position measurement devices. A fault in one of the above components or their improper combination or tuning may be the source of the fault. The TVR provides extensive diagnostics for rapid localization of faults.

6.2. Safety Guidelines

There is an increased chance of an accident when a fault occurs. Personnel, machines, and equipment are at risk.



Guidelines for the prevention of injury

Troubleshooting and repair of faults should be undertaken by qualified personnel only.

Danger due to drive travel:
While troubleshooting, undesired drive travel is possible.



Personnel must not remain in the hazardous area of the installation. Protective devices such as safety screens, covers, and light barriers must not be disabled. There must be free and ready access to the E-stop button.

When working in the hazardous area, please note:



Turn off all power to the installation for all work in the hazardous area. Lock out the installation so that power cannot be turned on. Wait out the discharge time of the DC voltages (approximately five minutes). Verify the voltage by measuring at terminals X9 (L+/L-) and X7 (EPU+/EPU-).

Danger from voltage carrying parts

Dangerous voltage can occur at the following connections:

- At all connections to the power supply and its associated chokes and capacitors , and especially at connections to mains 1U1, 1V1, 1W1 and 2U1, 2V1, 2W1.
- At the drive modules, at the motor, and at connections to the motor

**Before working on electrical equipment:**

- **Switch off power to the machine at the main switch and lock it out to prevent it from being turned on again.**
- **Wait for the DC bus to discharge (approximately 5 minutes). Verify the voltage by measuring at terminals X9(L+/L-) and X7(EPU+/EPU-).**
- **Do not run motors. Voltage is present at the motor connections if the motor is in motion.**

Before turning the equipment on:



Only turn power on if the safety touch-shielding delivered with the unit is mounted in place.

Guidelines for protecting the machine

To avoid damage to the machine:



- **Only qualified personnel should be permitted to commission the machine.**
- **Be sure that the E-Stop and travel limit switches function properly.**

Guidelines for protecting drive components

Before turning on power:



Verify the wiring with the TVR interconnect diagram and the wiring diagram of the machine.

Electrostatic charge

Electrostatic charge endangers electronic components.
Discharge all objects before they come into contact with the equipment.

6.3. Diagnostic display, fault list

Diagnostic Display Supply Module TVR 3.1

Note: Signals only apply if "+24V, ±15V/+5V"- displays continuous green light

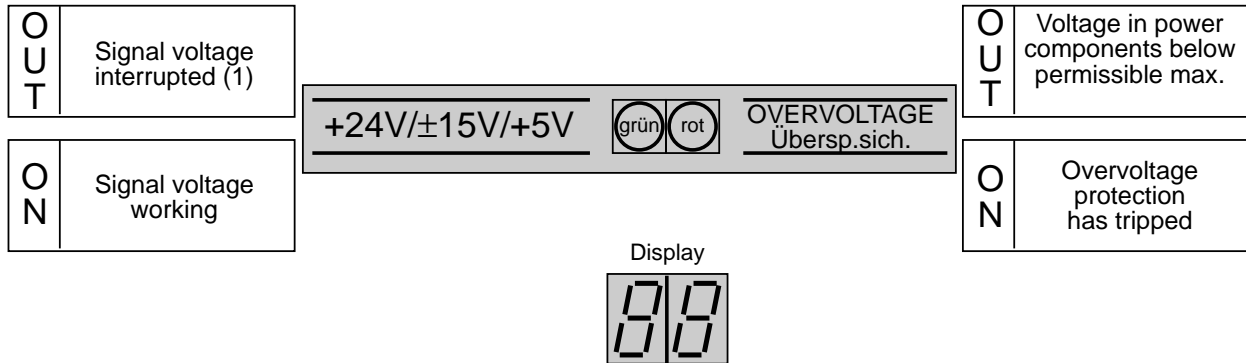

DISPLAY Anzeige	Description Bedeutung	Explanations
00	POWER Leistung	DC bus voltage within permissible range; TVR ready to supply power
01	LOWER OFF Leistung aus	Power relay in TVR deenergized
02	POWER OFF WITH ZKS Leistung aus mit ZKS	Power relay in TVR deenergized; DC bus short-circuit initiated
03	+24V/±15V FAULT Fehler	Signal voltage disrupted (1)
04	MAINS FAULT Netzfehler	No mains connection; no mains phase (1)
05	UD FAULT Fehler	DC bus voltage exceeds permissible limits
06	HEAT SINK TEMP. FAULT Kühlkörper Übertemp.	Power switched off due to equipment overtemperature (1)
07	BLEEDER OVERLOAD Überlast	Excessive braking energy when power shutdown (1)
08	EPU FAULT Fehler	Capacitor between X7/EPU* and X//EPU short-circuited or polarity is wrong
09	SOFTSTART-FAULT Softstartfehler	DC bus cannot be loaded (1)
10	OVERCURRENT Überstrom	Shutdown due to overcurrent, short-circuit in TVR, in drive module, in cable or in motor (1)
11	PROCESSOR FAULT Prozessorstörung	Problem with microprocessor in TVR (1)
12	DRIVE FAULT Antriebsfehler	Power turned off due to drive error
13	DEVICE DAMAGED Gerät defekt	Over voltage fuse blown
14	BRIDGE-FAULT Brücken-Fehler	Bridge voltage not achieved
15	MISWIRING Anschlußfehler	Phasing between power connection and electronic supply at terminals X7 is wrong.

(1) Signals and unit lockout are latched

Re-set by pressing reset button or by switching electronic supply back on

DATVREN

Figure 6.1: TVR 3.1 diagnostics displays

6.4. List of faults and their remedies

Message

+24 V/±15 V/+5 V
„OFF“



Signal voltage faulty

Possible causes:

- Missing or faulty mains input voltage for electronic supply.
- Signal voltage supply is overloaded.
- DC bus voltage is less than 180 V after a mains power failure.

Remedies:

- Check mains fuses in the control panel.
- Disconnect wire-ribbon connection to the drives and measure the voltages.
- Disconnect signal voltages pulled off the TVR or drive modules for external use in the control cabinet and check for short-circuits.

OVERVOLTAGE
„ON“



Overvoltage protection circuit in TVR has tripped

Possible causes:

- A fault in the TVR high voltage section
- Unit defective caused because mains voltage was too high

Remedies:

- Check mains voltage; should not exceed 480 VAC +10%
- Replace the TVR

Display**TVR power contactor has dropped out**

Possible causes:

- OFF or E-Stop button is pressed.

Remedies:

- Turn on power.
- Check the TVR connections.

**TVR power contactor has dropped out;
DC bus short-circuiting activated**

Possible causes:

- The machine's controller initiated DC bus short-circuiting.

Remedies:

- Check the E-Stop chain of the machine (overtravel limit switches, Bb1 contact of the TVR, servo fault signal from the NC, wiring).

**Signal voltage fault**

Possible causes:

- Mains connection to electronics supply is open or faulty.
- Signal voltage supply is overloaded.
- DC bus voltage is lower than 180 V after a mains power failure.

Remedies:

- Check mains fuses in the control cabinet.
- Disconnect wire-ribbon connection to the drive modules and measure the voltages.
- Disconnect signal voltages pulled off the TVR or drive modules for external use in the control cabinet and check for short-circuits.

**Mains voltage fault**

Possible causes:

- Mains fuses burned out.
- Mains phase is missing.
- Mains voltage is too low.

Remedies:

- Check mains connection at terminal X7 for 3 x 380 ... 480 VAC $\pm 10\%$

**The DC bus voltage not within permissible limits**

Possible causes:

- Mains voltage is too high or too low.
- DC bus choke is not connected or incorrectly connected.
- Fault in the TVR.

Remedies:

- Check mains voltage: 3 x 380 ... 480 VAC $\pm 10\%$
- Check connections to the DC bus choke; the choke must be connected between X7/1L+ and X7/2L+.

Display



Shutdown due to equipment overtemperature

Possible causes:

- TVR power section is overloaded.
- Ambient temperature is too high.
- Unit blower has failed.
- Fault in the TVR.

Remedies:

- Check the load.
- Monitor the TVW contact.
- Check the ambient temperature.



Braking energy too high with power turned off

Possible causes:

- Energy in the axes is too high.
- Too many braking procedures with the power off.

Remedies:

- Check the energy of the axes.
- Provide a delay for the OFF and E-Stop signals.



Capacitance between terminals X7/EPU+ and X7/EPU- with wrong polarity or has a short circuit

Possible causes:

- Capacitor is defective.
- Capacitor connected with wrong polarity.
- Wiring is faulty.

Remedies:

- Disconnect the capacitor.
- Check the wiring.
- Fault in the TVR.

Display**DC bus cannot charge up**

Possible causes:

- Too many capacitors on the DC bus.
- Short circuit in the TVR.
- Short circuit in a drive module.
- DC bus choke not connected or incorrectly wired.
- Optional DC bus capacitors short-circuited or their polarity is wrong.

Remedies:

- Disconnect the added capacitors.
- Disconnect the busbars to the drives.
- Check the connection of the DC bus choke; the choke must be connected between terminals X7/1L+ and X7/2L+.
- Check the wiring of the optional DC bus capacitors.

**Shutdown due to overcurrent**

Possible causes:

- Defective drive module
- Short circuit in the TVR.
- Damaged motor power cable.
- Short circuit in the motor windings.

Remedies:

- Disconnect the busbars.
- Check the drive module and its associated motor and cables.

**Microprocessor fault in the TVR**

Possible causes:

- Program run disturbance

Remedies:

- Turn power supply off, then on again.
- Replace the TVR.

**Shutdown due to drive fault**

Possible causes:

- Fault in the drive module, the feedback cable, the motor power cable, or in the motor.

Remedies:

- Check the drive module diagnostics.
- Sequentially disconnect busbars and wire-ribbon connections to the drive modules and press the RESET button.

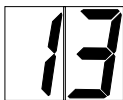
Display-**TVR overvoltage protection has tripped**

Possible causes:

- Fault in the high voltage section of the TVR.
- TVR defective because mains voltage is too high.

Remedies:

- Check mains connection at terminal X7 for 3 x 380 ... 480 VAC $\pm 10\%$
- Replace the TVR.

**DC bus voltage is too low**

Possible causes:

- Mains protective device has tripped.
- Mains voltage is too low.

Remedies:

- Check mains connection at terminals X7 for 3 x 380 ... 480 VAC $\pm 10\%$
- Reset the fault by switching off control voltages.

**Phases are mismatched between the high voltage section and the electronics section**

Possible causes:

- Connections to the electronics section are cross-phased.

Remedies:

- Check the voltages at terminal block X7.

The voltages across terminals

1U1 and 2U1

1V1 and 2V1

1W1 and 2W1

should be zero volts.

**Check sum error**

Possible causes:

- EPROM in TVR is defective.

Remedies:

- replace TVR

7. Dimensions

7.1. Dimension sheet TVR 3.1 power supply module

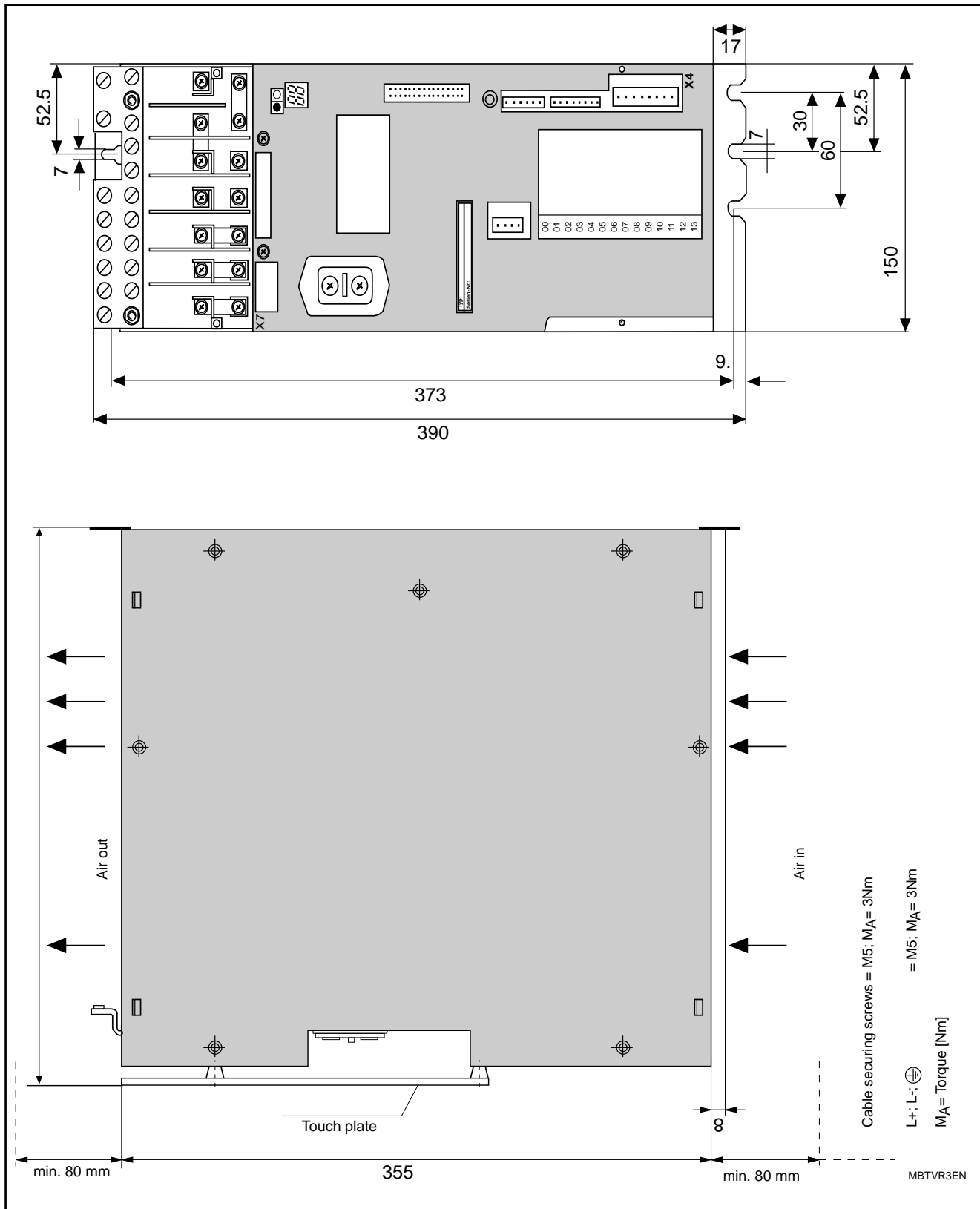

Fig. 7.1: Dimension sheet for TVR 3.1 power supply module

7.2. Smoothing choke dimension sheet

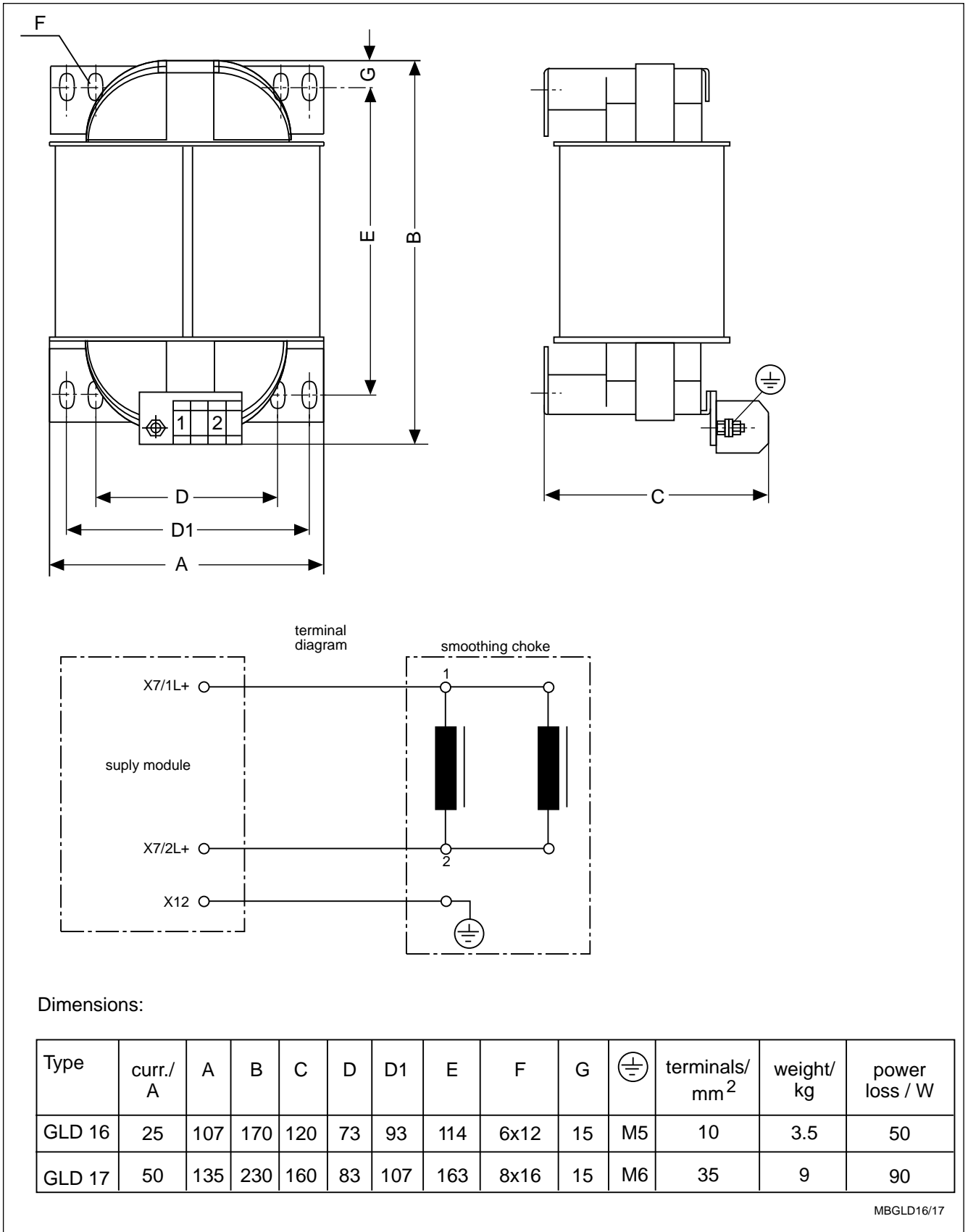

Fig. 7.2: Smoothing choke GLD 17 dimension sheet

7.3. Commutation choke dimension sheet

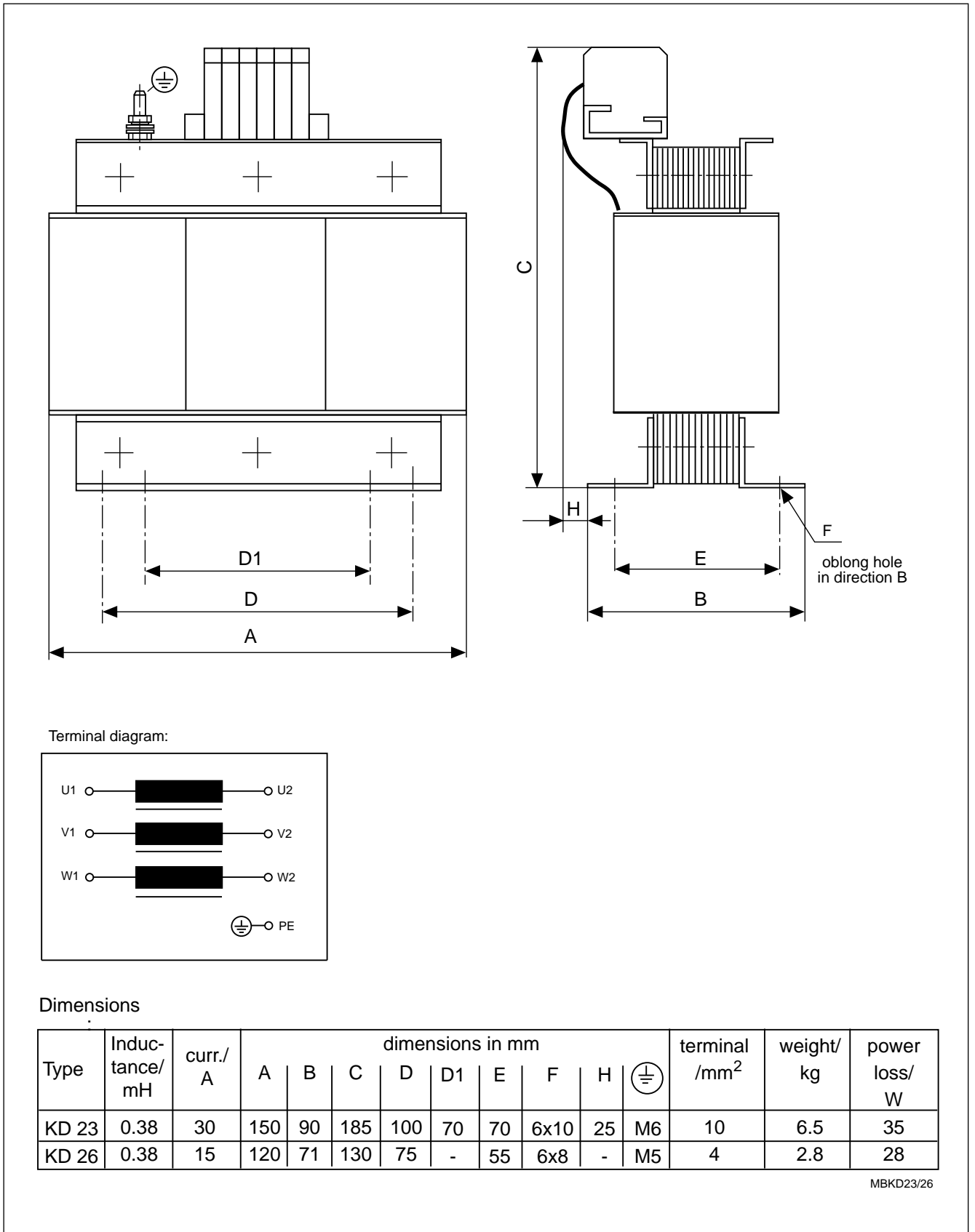

Fig. 7.3: Commutation choke dimension sheet

7.4. NAM 1.2 dimension sheet

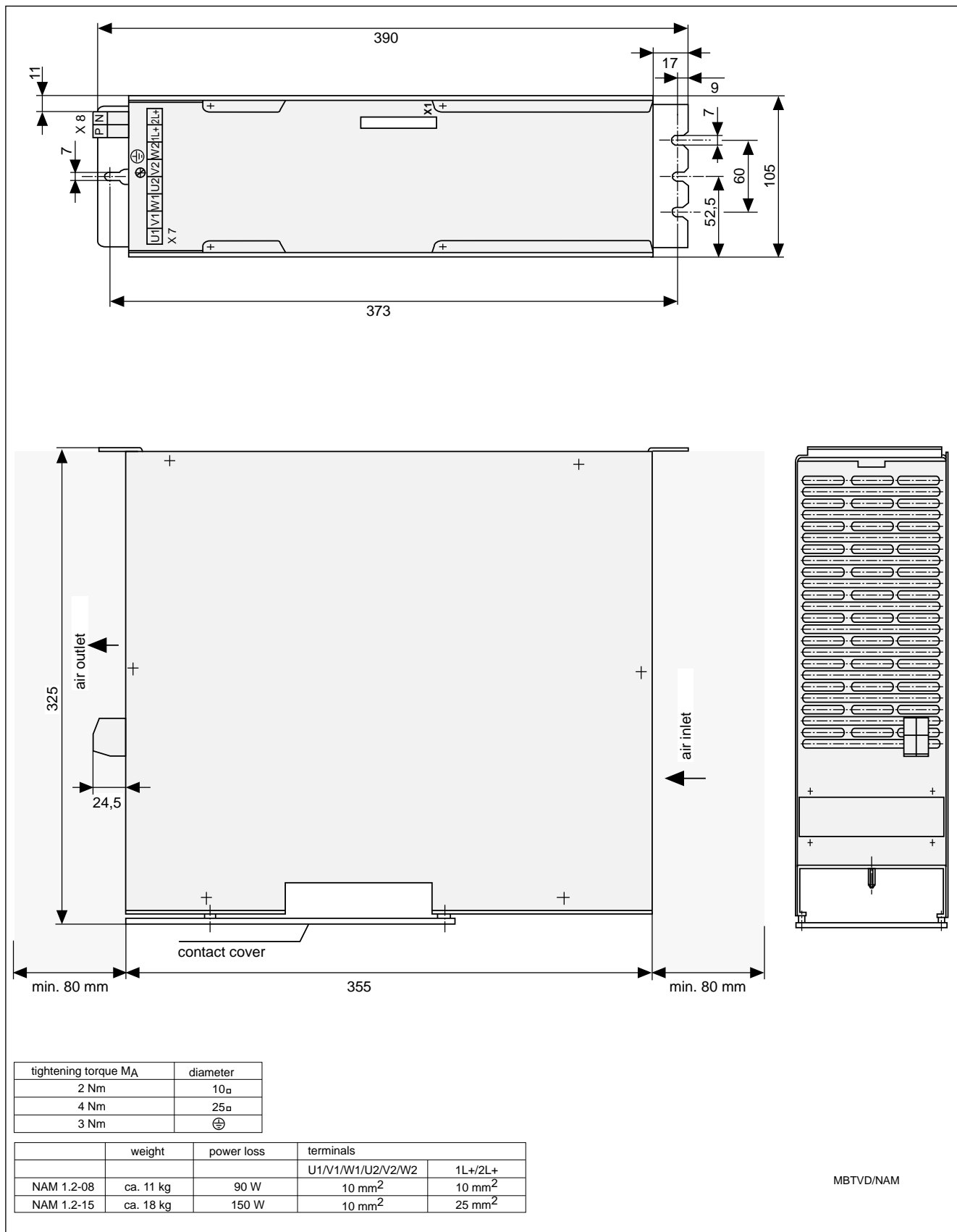

Figure 7.4: NAM 1.2 power supply module - dimension sheet

7.5. TCM 1.1 auxiliary capacitance module

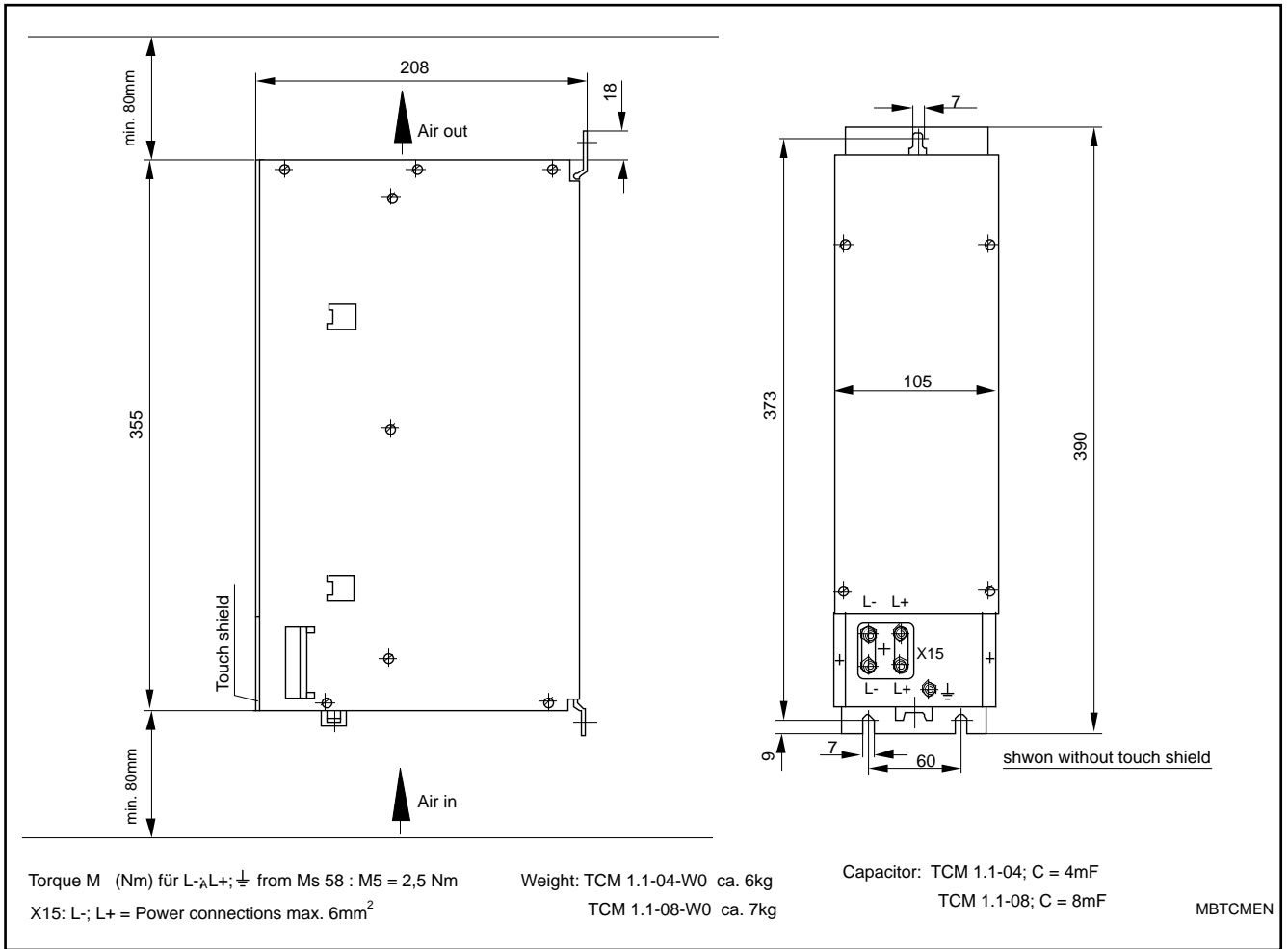

Figure 7.5: TCM 1.1 auxiliary capacitance module - dimension sheet

7.6. CZ 1.02 DC bus voltage capacitor

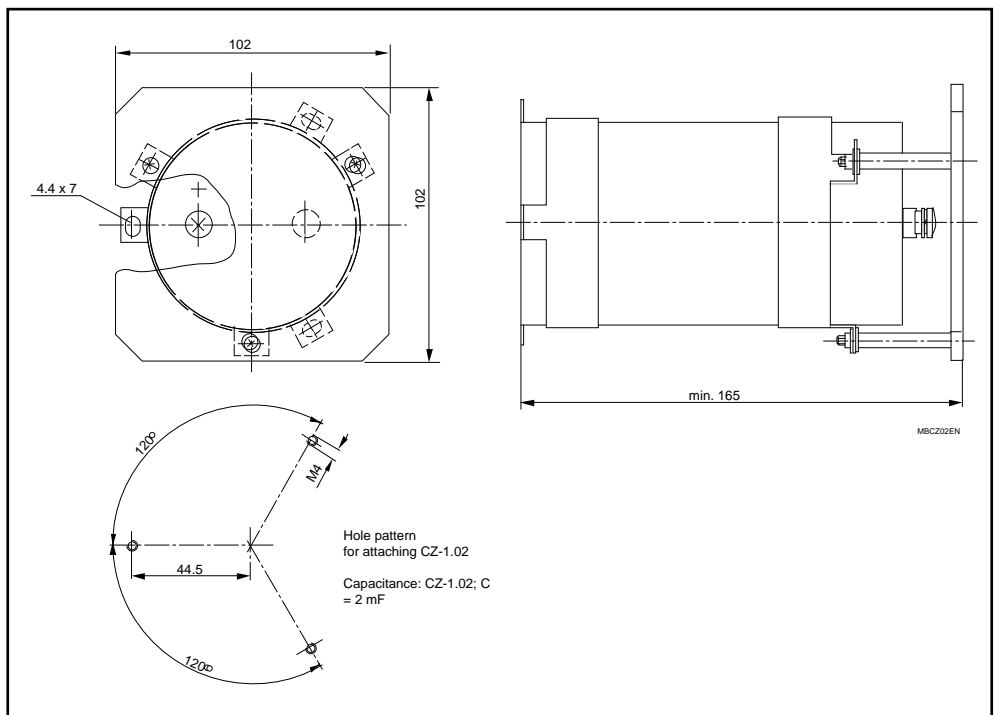

Figure 7.6: CZ 1.02 DC bus voltage capacitor - dimension sheet

7.7. TBM 1.2 auxiliary bleeder module dimension sheet

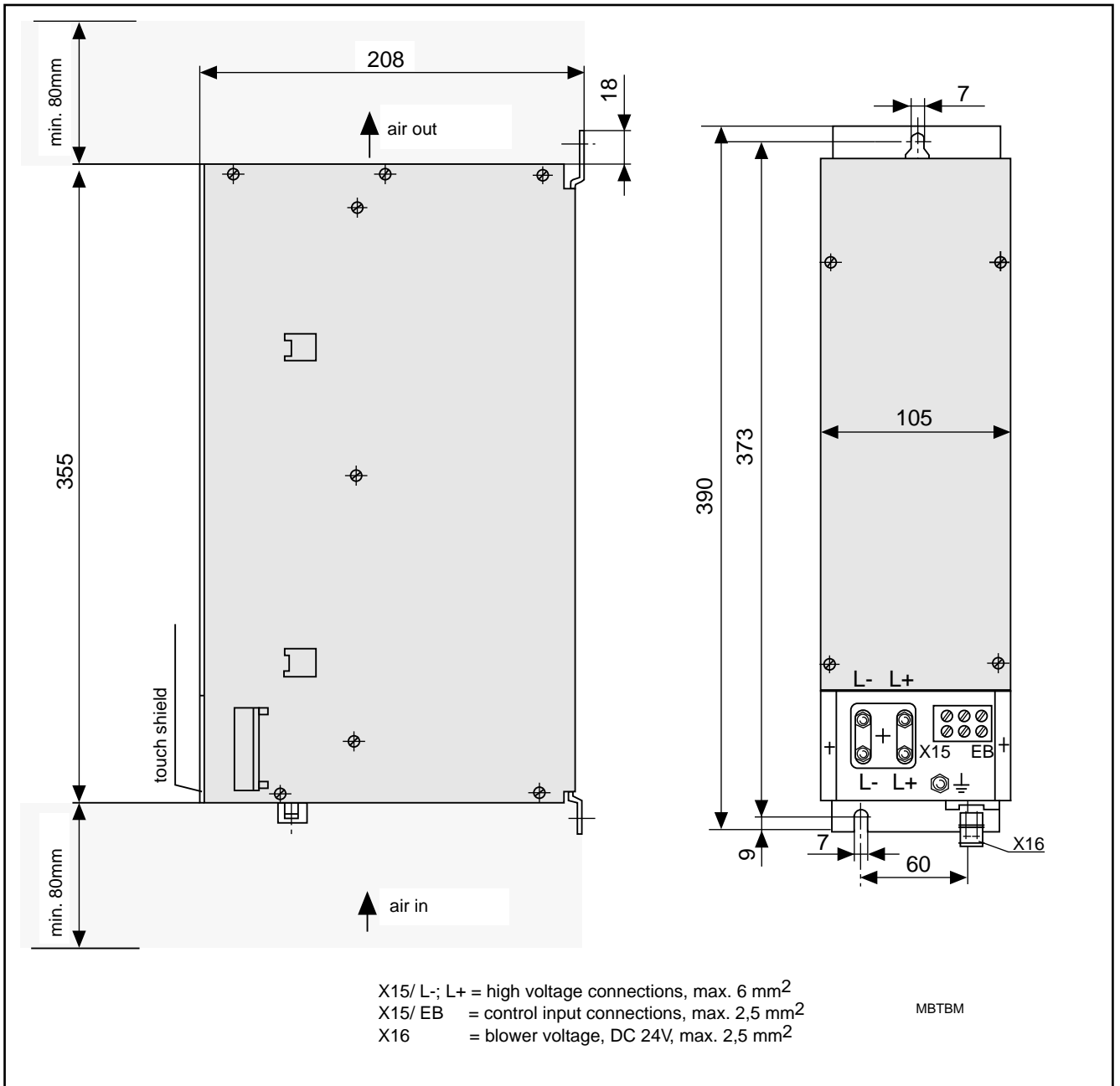

Fig. 7.6: TBM 1.2 auxiliary bleeder module dimension sheet

8. Order information

8.1. TVR 3.1 type codes

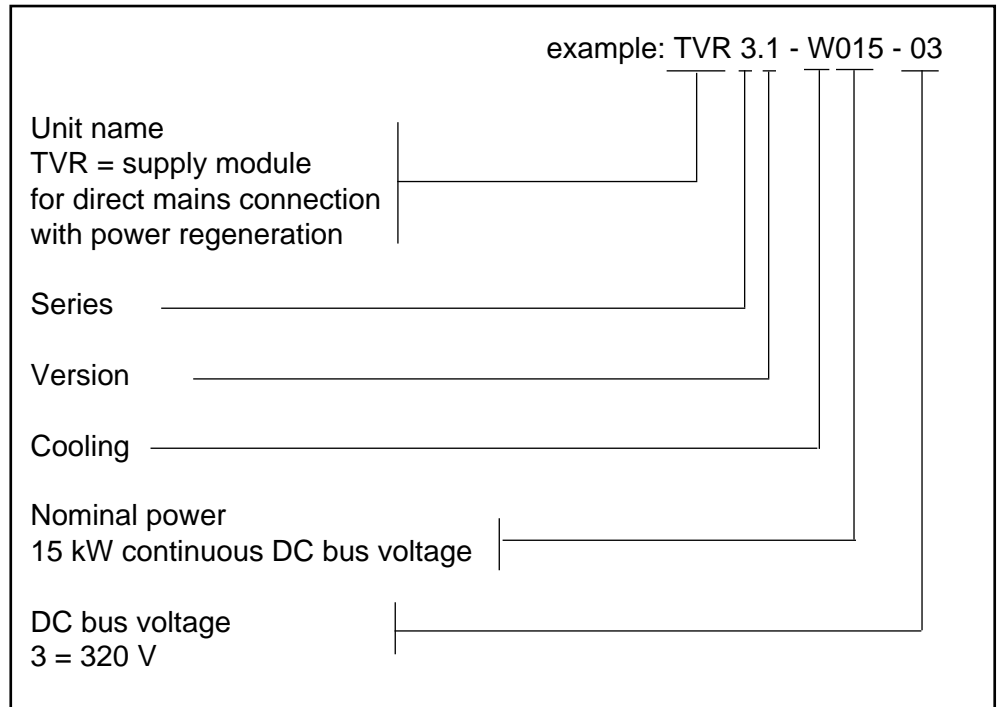

Fig. 8.1: Type codes

8.2. Available configurations of the TVR 3.1 power supply module and accessories

Designation	Available configurations
1. Power supply module	TVR 3.1-W015-03
1.1 Electrical accessories	E1-TVR E2-TVR E3-TVR
2. Inductors	
2.1 DC bus smoothing choke and commutation choke or mains supply module and wire-ribbon cable IN ... / ...	GLD 17 KD 23 NM 1.2-15 (see section 8.4)
3. Auxiliary bleeder module	TBM 1.2-040-W1/024

8.3. Overview of electrical accessory kits

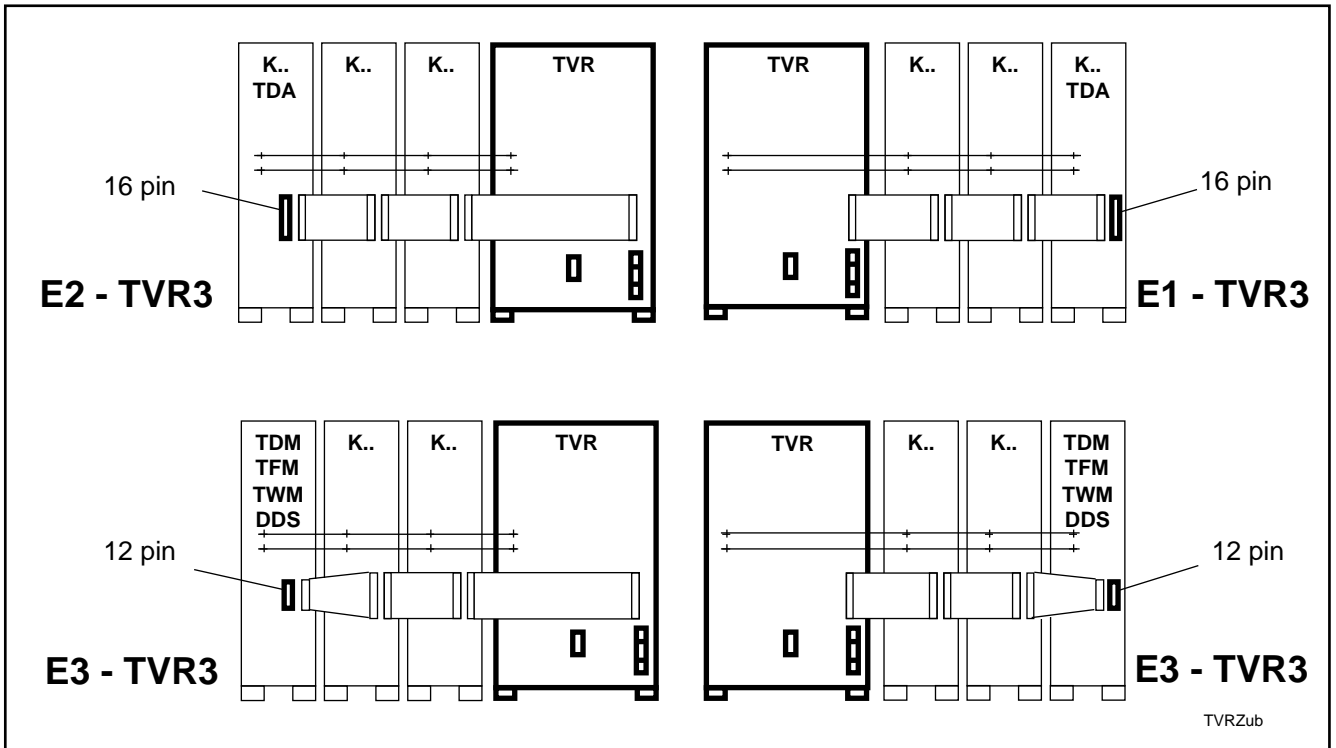

Fig. 8.2: Overview of electrical accessory kits

8.4. Overview 16-pin bus cable for NAM 1.2

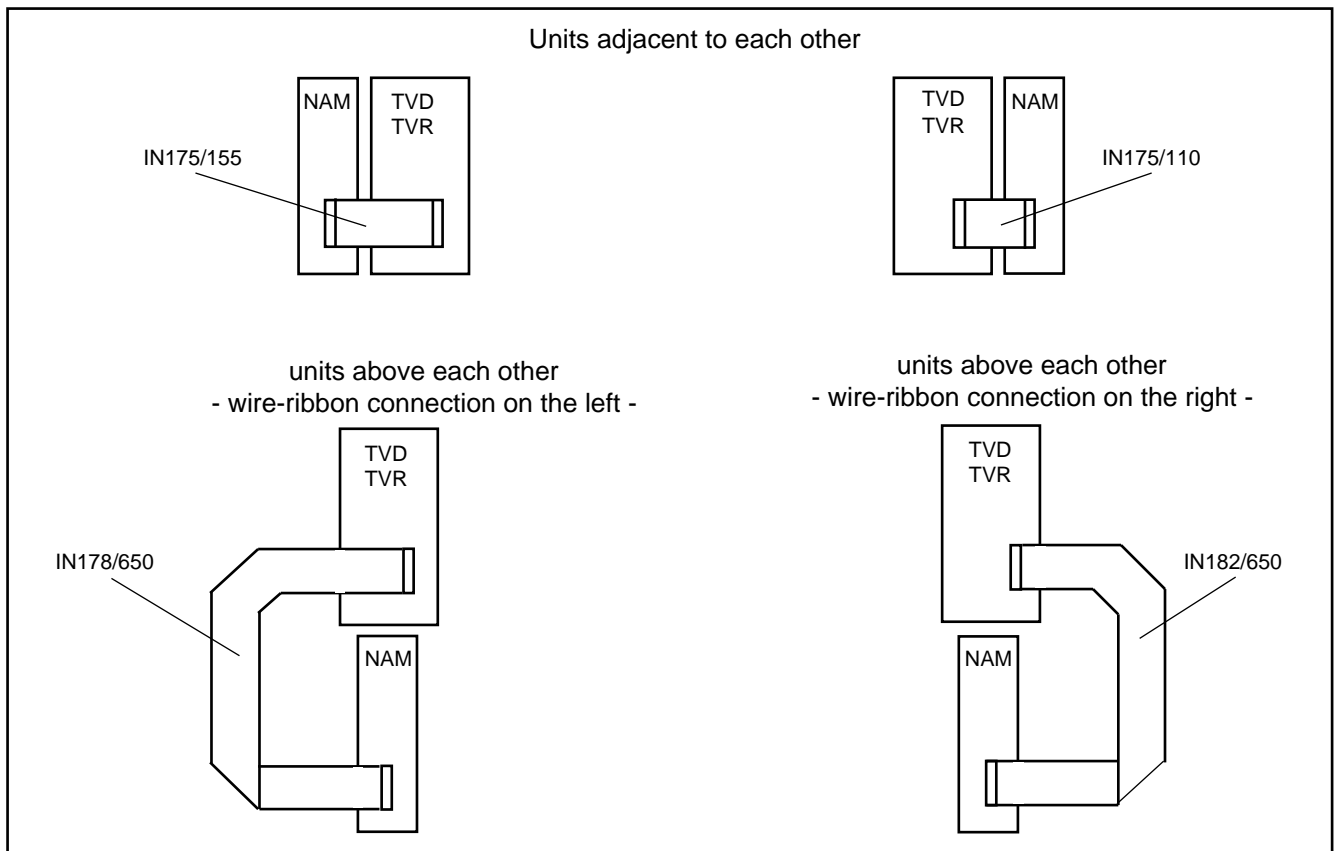

Figure 8.3: Bus cable

8.5. Parts list for the TVR 3.1 power supply module

Item	Article	Selection, see
1.1	TVR 3.1-W015-03	
1.2	Electrical accessories E-TV	section 8.3
2.1	DC bus smoothing choke GLD 17	
2.2	Commutation choke KD 23	

9. Index

A

AC drive system 6
Adding capacitance 21
Additional bleeder module 21
Ambient temperatures 11
Arranging the Drives 25
Asynchronous drives 32
Asynchronous main drives 30
Asynchronous motors 29
Auxiliary bleeder module 9
Available configurations 58

B

Basic losses 27
Bb1 contact 7, 40
Bb1 Output 40
Bleeder 6
Bleeder resistor 7, 27, 30, 32, 36
Braking energy 49
Busbars 20

C

Check sum error 51
Commutation choke 9, 16, 20
Commutation choke dimension sheet 54
Control cabinet testing 25
CZ 1.02 DC bus voltage capacitor 56

D

DC Bus 21
DC bus input 38
DC bus short-circuit 6, 7
DC Bus short-circuiting 29
DC bus short-circuiting 32, 38, 40
DC bus voltage 48
DC bus voltage circuit 20
DC continuous power 9
DC peak power 9
DC short-term power 9
Diagnostic display 46
Dimensions 52
Direct connection to mains 16
Drive fault 50
Drive module 6

E

E-Stop 30, 32
E-stop relay 32
Electrical accessory kits 59
Electronic power supply 7, 10
Electronic supply 22
Electronically coupled gearboxes 36

Electronics supply 23
Electronics supply buffer capacitor 23
Electrostatic charge 45
End plug 24
Energy stored 21
Environmental conditions 10

F

Fan Supply 22
Fault list 46
FI type current limiting circuit breakers 24
Front view 28
Fuse 12
Fuse protection 18

G

GLD 17 DC bus choke 21
Ground wire 16
Grounded threephase mains 18
Grounded wye or delta system 18
Guidelines for protecting personnel 45

H

High overload capacity 12
High voltage rectifier 7
High voltage section 51
High voltage test 25
Hold high 38

I

Input voltage 22
Installation altitudes 11
Installation requirements 25
Interconnect diagram 14
Inverter 7

K

K1NO and K1NC2 output 43
K1NO Output 43
KD 23 commutation choke 20

L

Leakage current 24
Leakage current protective devices 24
Localizing the fault 44
Losses of High Voltage Section 27

M

Main contactor 40
Main power contactor 38
Mains connection - high voltage section 16
Mains contactor 7
Mains current 18
Mains power failure 42

Mains protective device 51
Mains voltage 18, 48
Maximum additional capacitance 21
Maximum fusing 18
Microprocessor 50
Monitor circuits 34
Monitoring 7
Mounting 25

N

NAM 1.2 dimension sheet 55
NAM 1.2-15 power supply pack 9
NC control unit 36
NCB link 36, 39
Non-periodic overvoltages 19

O

OFF Input 38
ON impulse 38
ON Input 38
Order information 58
Overcurrent 50
Overcurrent protection 12
Overtemperature 49
Overvoltage 18, 19
Overvoltage protection 47, 51

P

Peak bleeder power 9
Peak regenerated power 21
Periodic overvoltage 19
Phases 51
Position-controlled 29, 36
Power contactor 48
Power failure 7, 23, 30, 34, 39
Power OFF 38
Power ON 38
Power ratings 9
Power supply 8
Prevention of injury 44
Protecting drive components 45
Protecting the machine 45

R

Ready state 7
"Ready" status 40
Regenerated energy 8
rf interference filter 16, 24

S

Safety clearance 27
Safety Guidelines 44
Signal exchange 23
Signal voltage bus 7
Smoothing choke dimension sheet 53

Spacing dimensions 26
Supply module 6
Synchronous drives 32
Synchronous drives 30
Synchronous motor 32
Synchronous motors 29, 30

T

TBM 1.2 21
TBM 1.2 auxiliary bleeder module dimension sheet 57
TCM 1.1 auxiliary capacitance module 56
Temperature pre-warning 42
Transformer 17
Troubleshooting 44
TVR 3.1 - data sheet 10
TVR 3.1 interconnections 29
TVR grounding requirements 18
TVR mains contactor 43
TVW output 42
Type codes 58

U

UD contact 36, 42
UD output 42
Ungrounded threephase mains 18

V

Voltage carrying parts 45

W

Wire ribbon cabl 23
Wiring diagram 13

